

NOUVEAU PAYSAGE

Chair mutation des vies étudiantes

LE CROUS CACHAN

Un constat



UN PAQUEBOT INOCCUPÉ



UNE ESPLANADE VIDE



PETITE CUISINE



CHAMBRE MONOTONE



Nouveau Paysage

Chair mutation des vies étudiantes
© Jingyu Yan - Carla Genty - Diane-Line Farré

UNE PROBLÉMATIQUE

*Comment préserver la santé mentale
des étudiants,
leur bien-être,
en apportant de la légèreté
dans le quotidien ?*

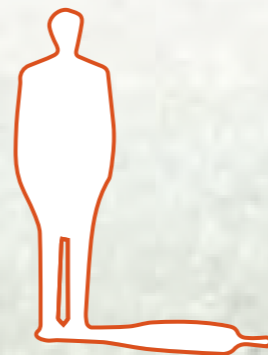

LE CROUS CACHAN

Immersion dans le paysage étudiant



UN PAYSAGE MULTIPLE

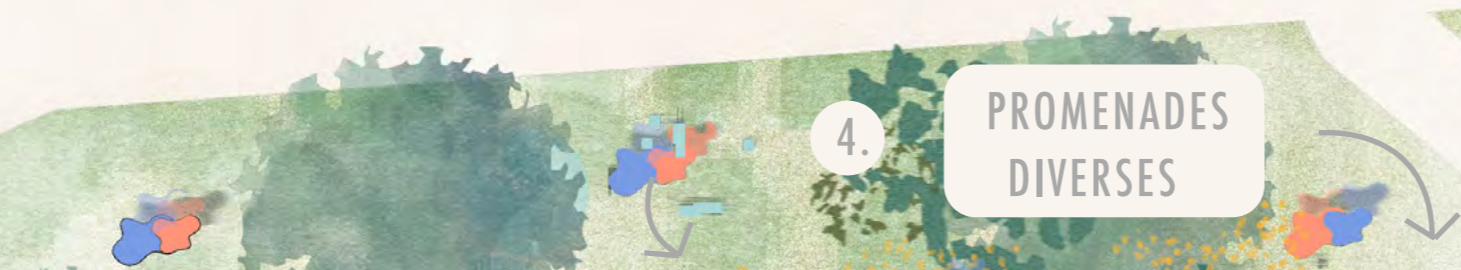
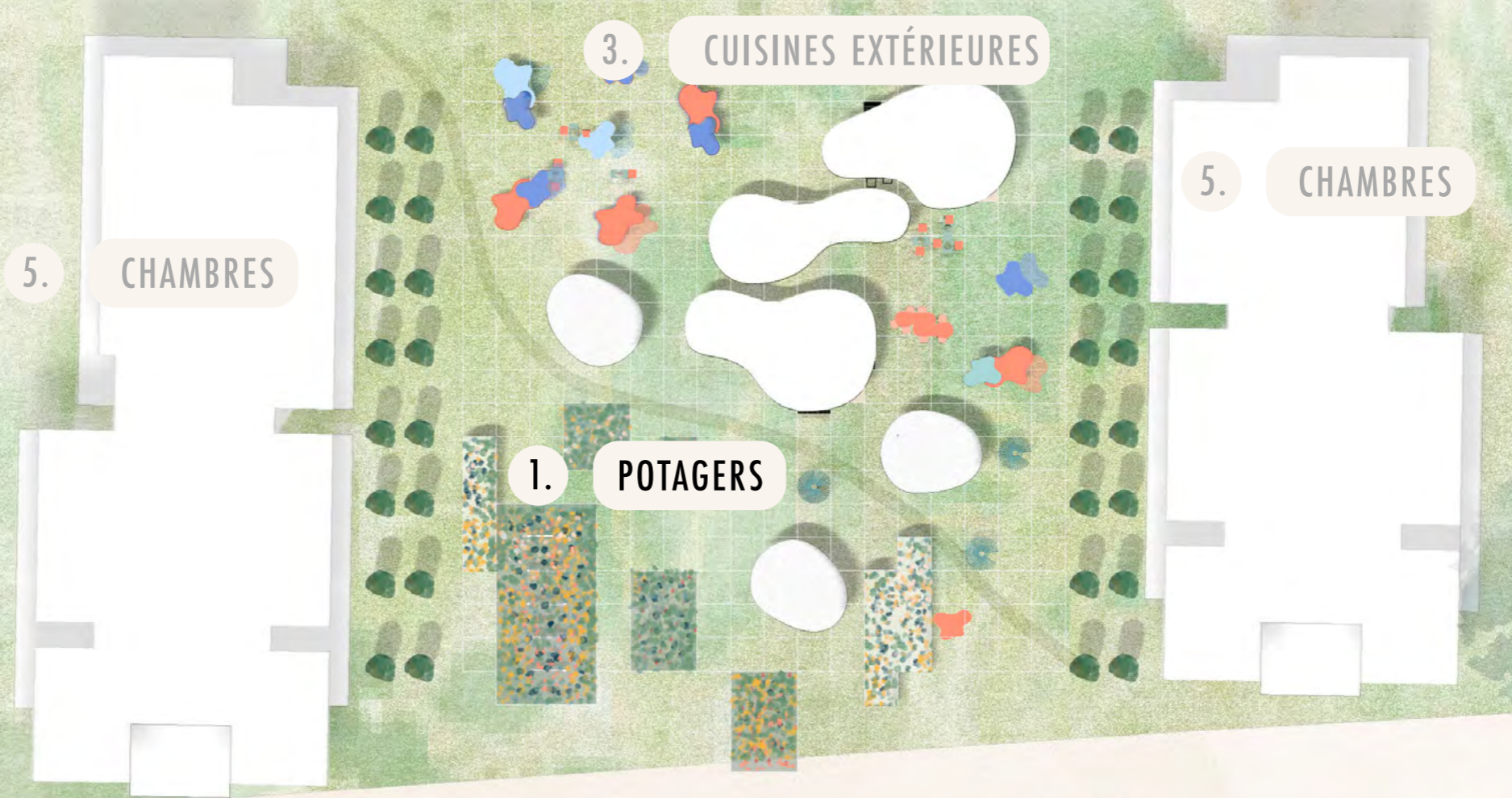
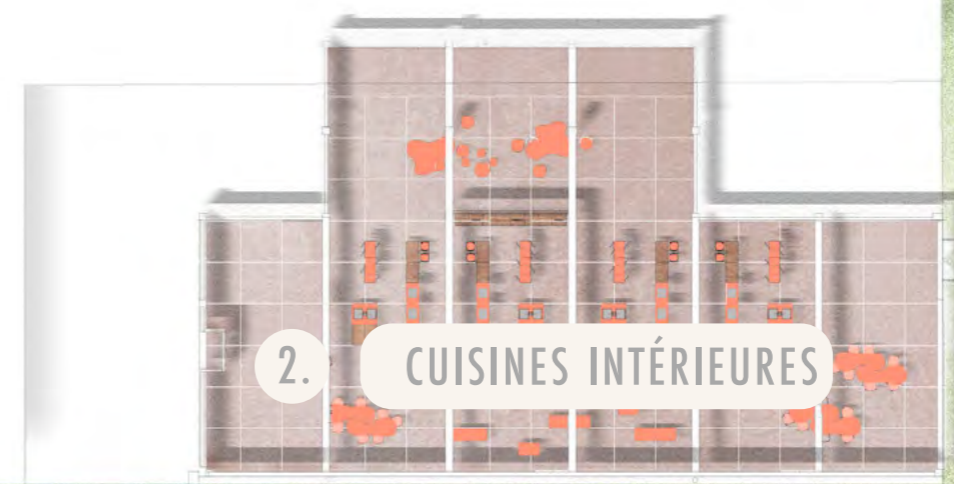

LE POTAGER PARTAGÉ

Regarder ses plantes,

Se promener autour...

DES ABRIS À OUTILS

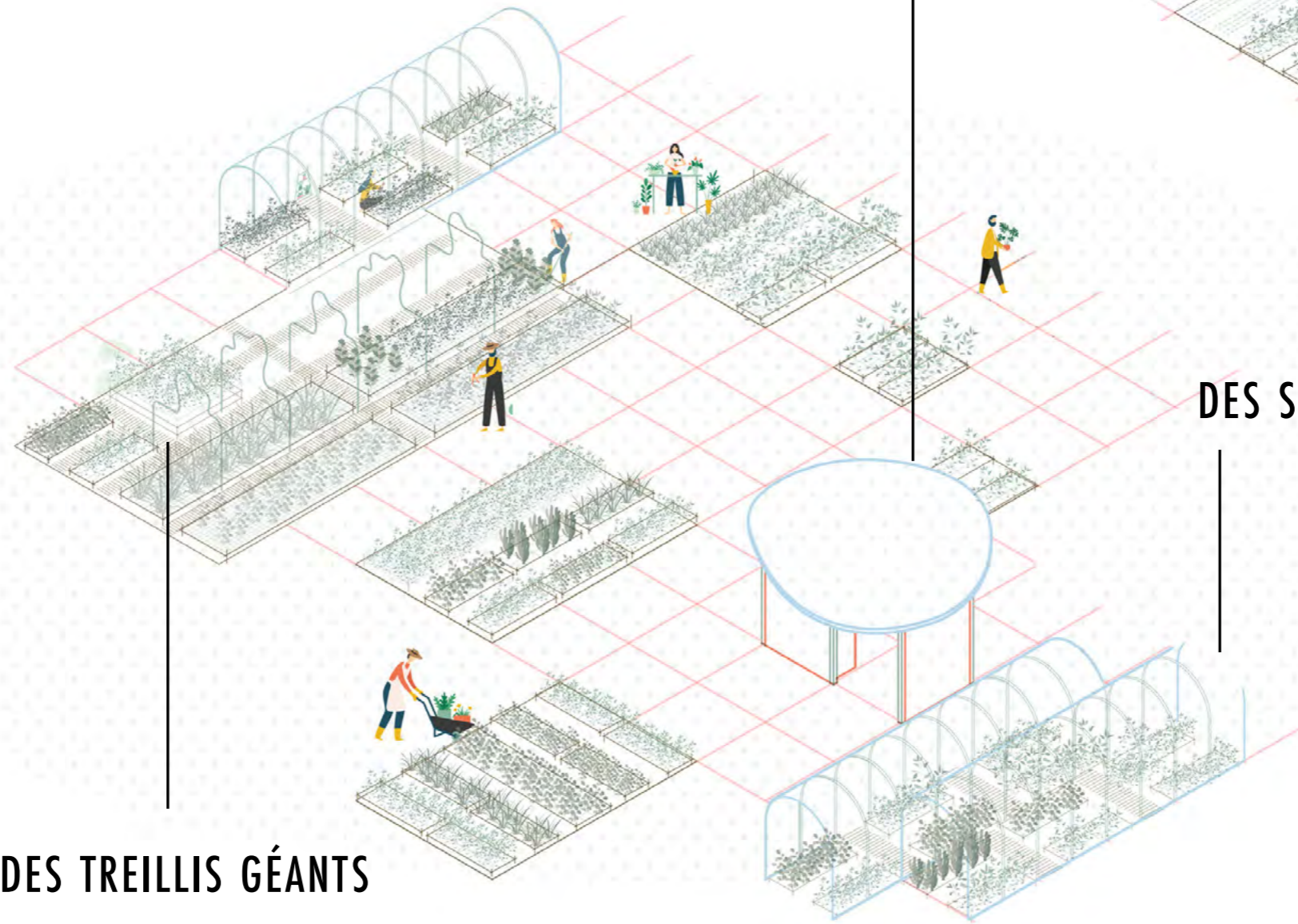
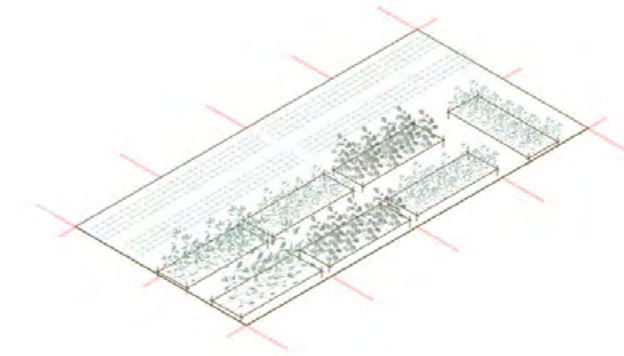

DES SERRES

DES TREILLIS GÉANTS

Nouveau Paysage

Chair mutation des vies étudiantes

© Jingyu Yan - Carla Genty - Diane-Line Farré

LE POTAGER PARTAGÉ

MOBILIER MOBILE

CHEMINS

DES SERRES

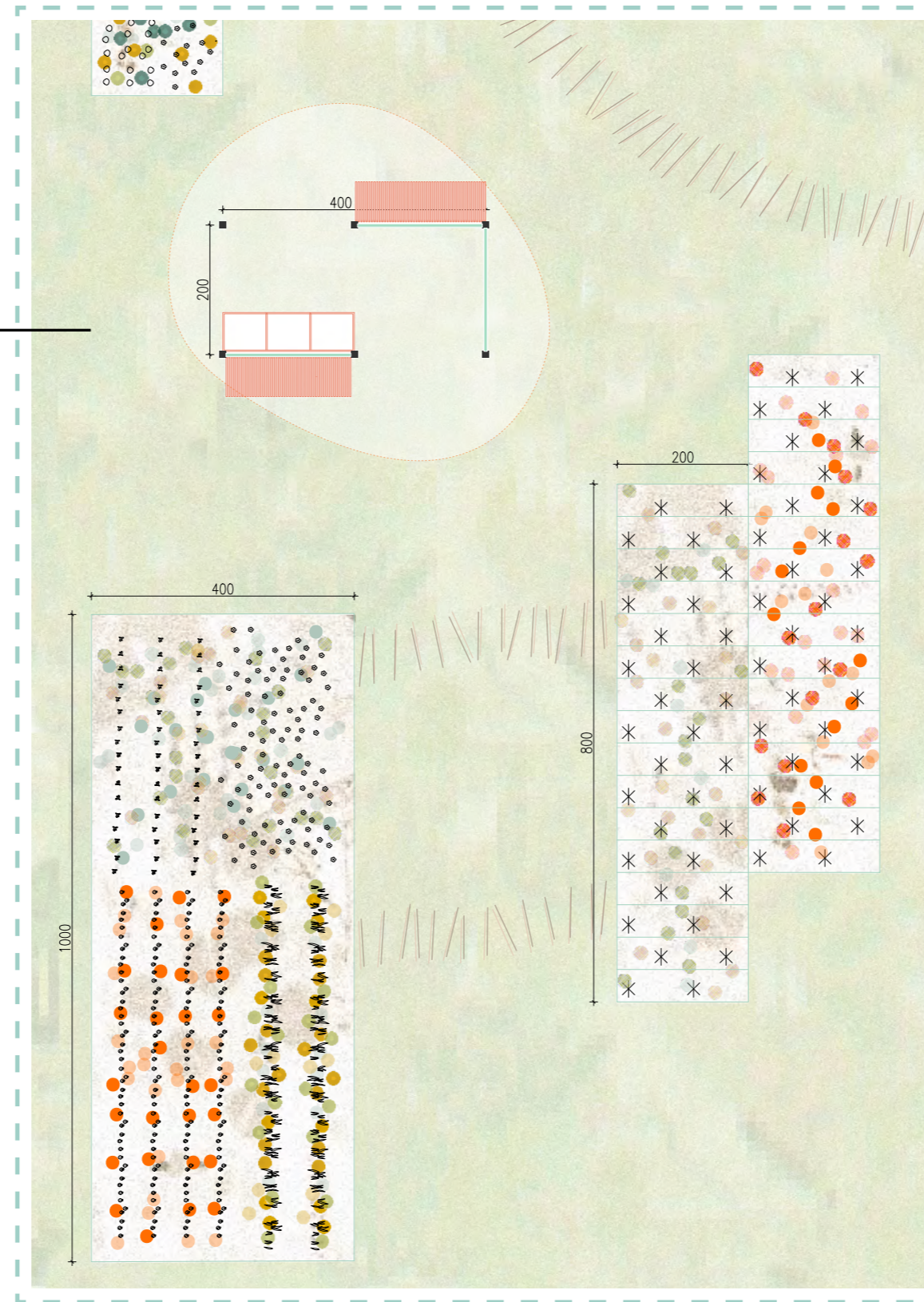

Nouveau Paysage

Chair mutation des vies étudiantes

© Jingyu Yan - Carla Genty - Diane-Line Farré



UN PAYSAGE MULTIPLE

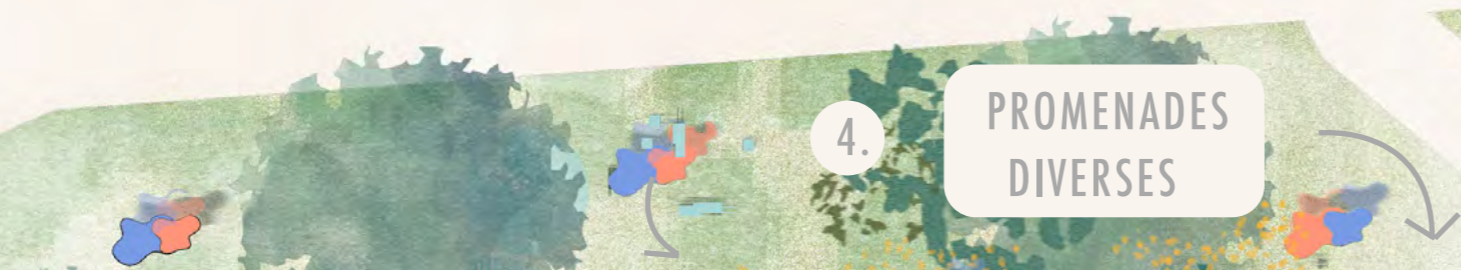
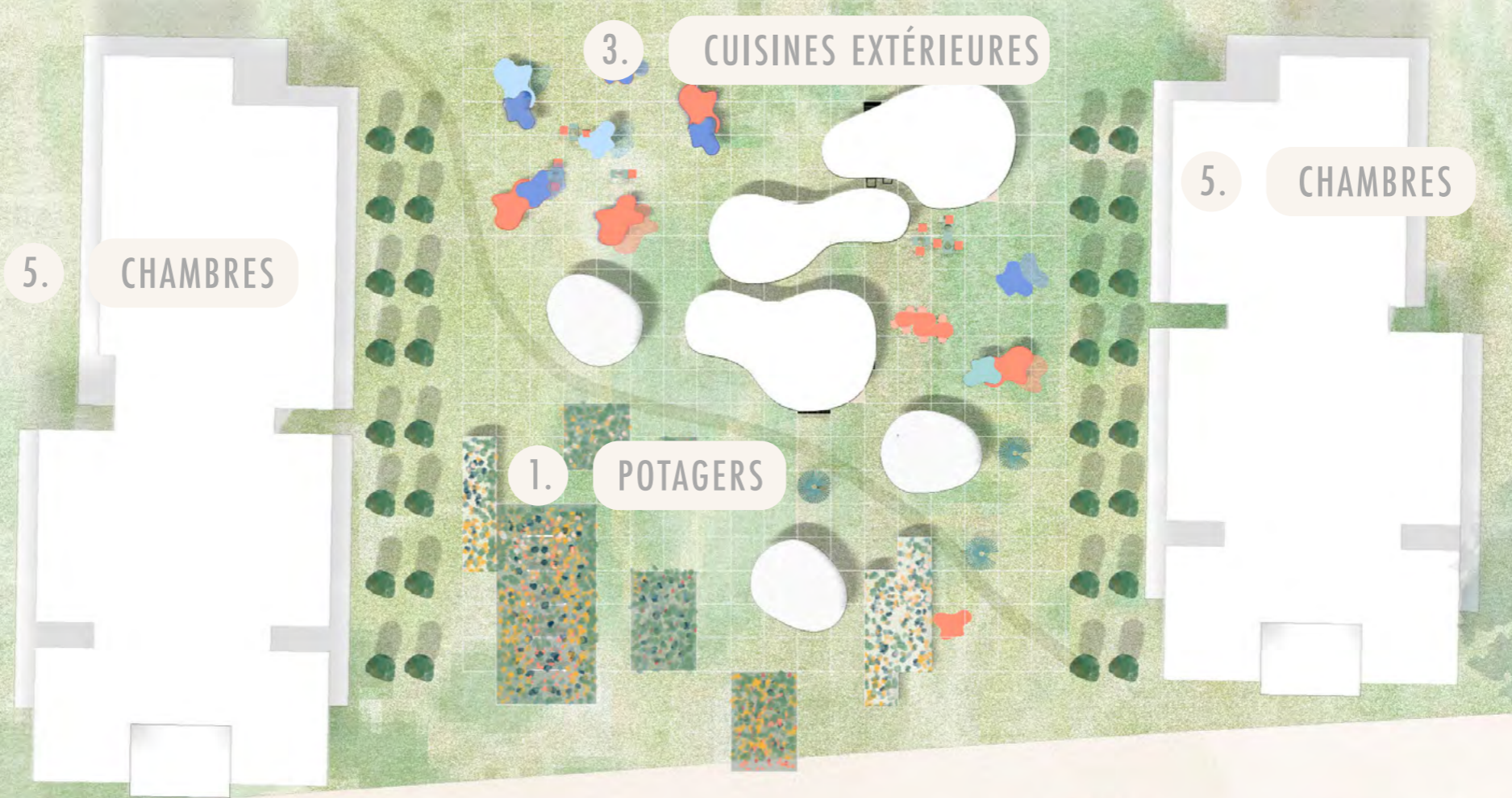
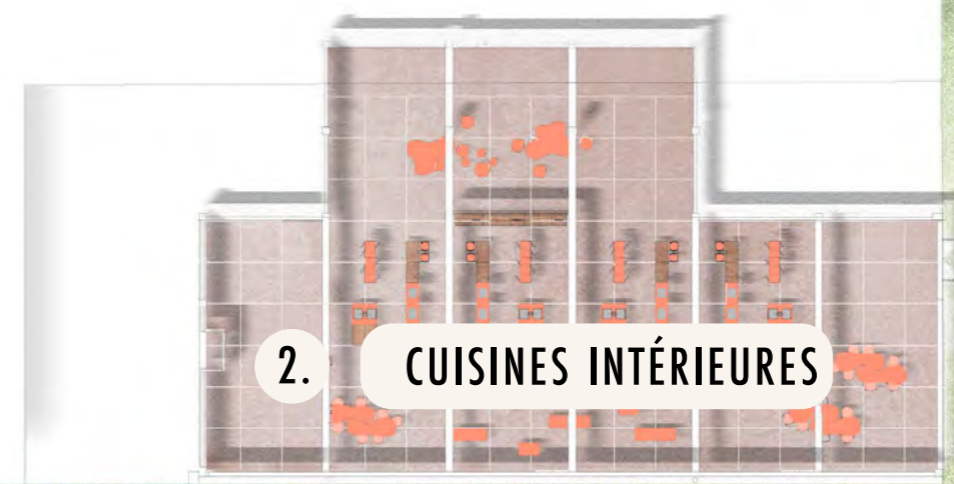

DES CUISINES INTÉRIEURES

*Cuisiner, bavarder,
prendre un verre, manger
et apprendre...*

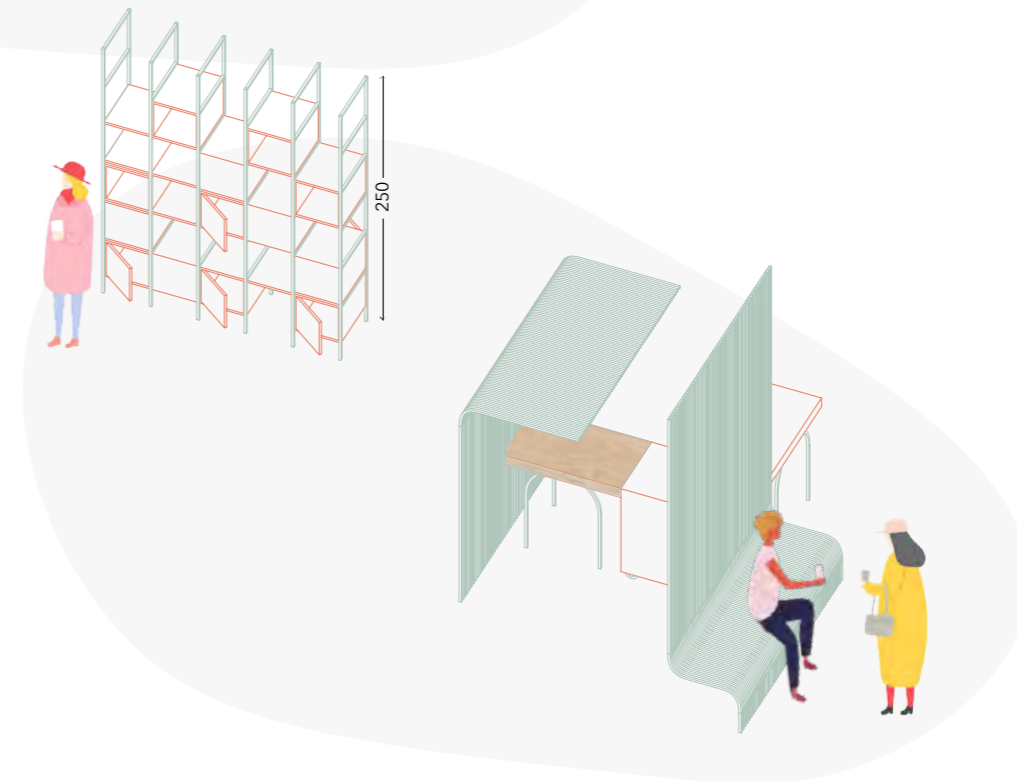
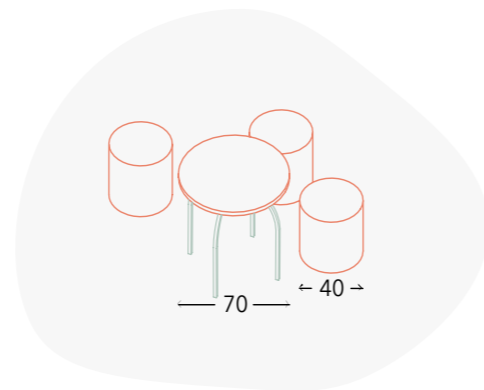
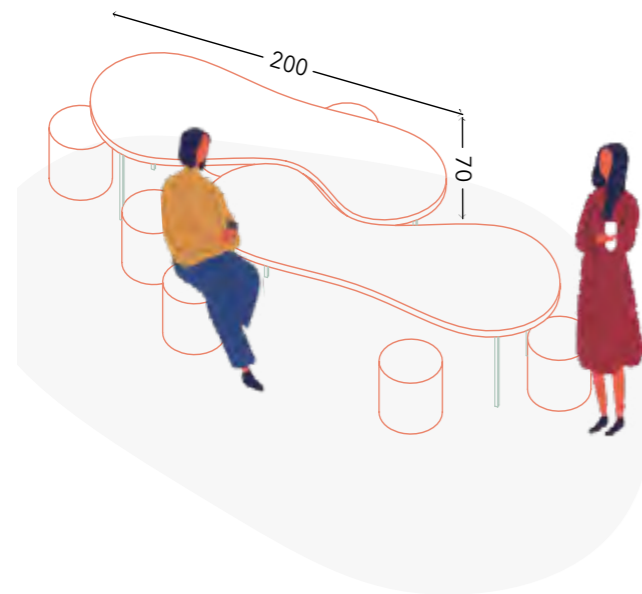

Nouveau Paysage

Chair mutation des vies étudiantes

© Jingyu Yan - Carla Genty - Diane-Line Farré

DES CUISINES INTÉRIEURES

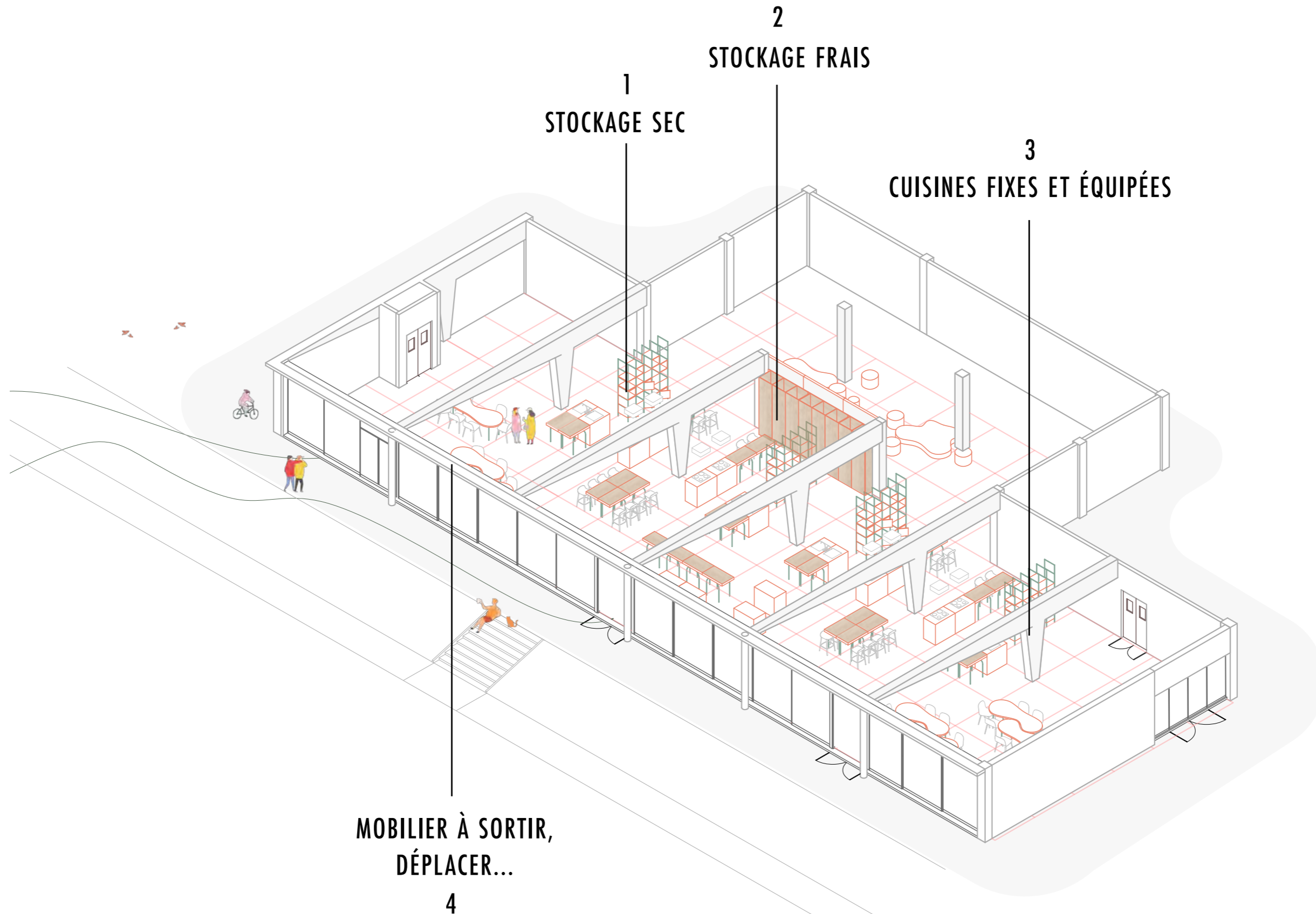

**MOBILIER À SORTIR,
DÉPLACER...**

4

Nouveau Paysage

Chair mutation des vies étudiantes

© Jingyu Yan - Carla Genty - Diane-Line Farré

**DES POUFS, COUSSINS ET ASSISES
SUR ROULETTES À DÉPLACER**

**UN MUR OÙ PROJETER DES
FILMS ?**

Vivre

Rencontrer

Partager une cuisine

un repas...

L'ÉVÈNEMENT ?

*Proposer des événements
avec le personnel du
restaurant*

*Organiser une vente
hebdomadaire de produits
alimentaires locaux sous la
«halle»*

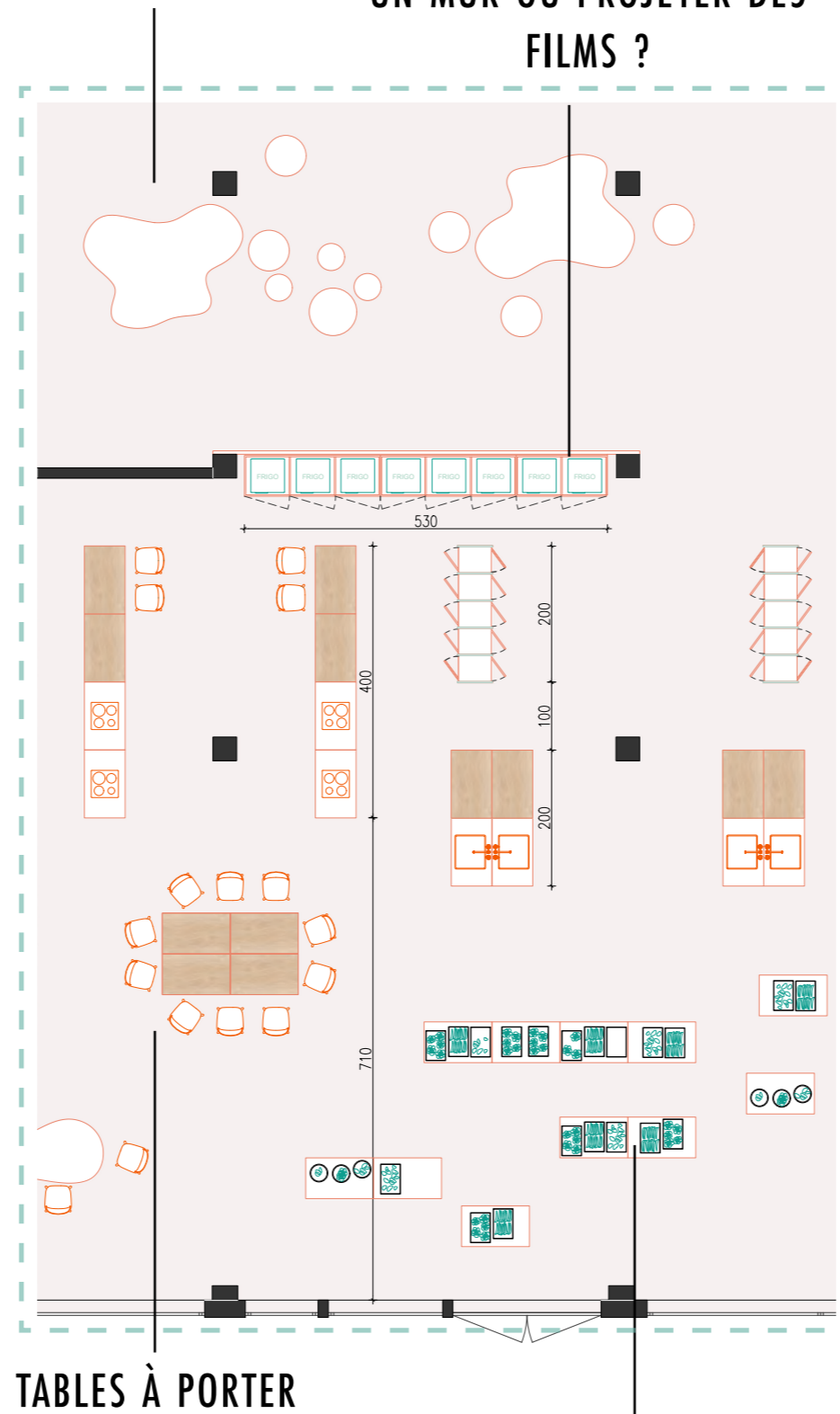

*Et si on zoomait dans les
cuisines ?*

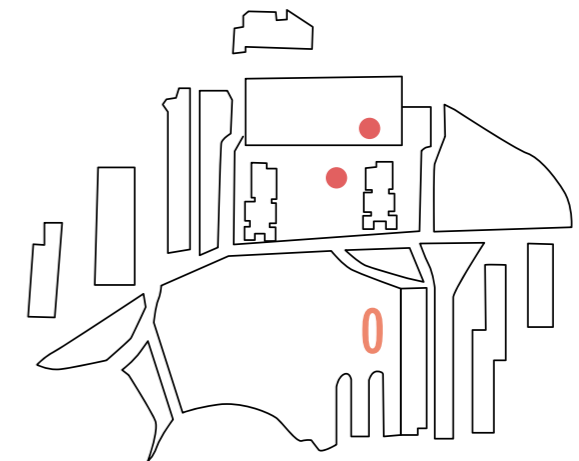

Nouveau Paysage

Chair mutation des vies étudiantes

© Jingyu Yan - Carla Genty - Diane-Line Farré

UN PAYSAGE MULTIPLE

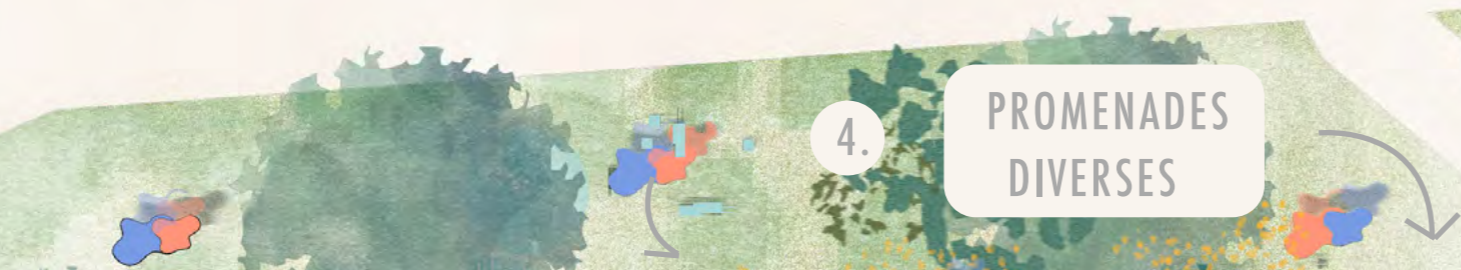
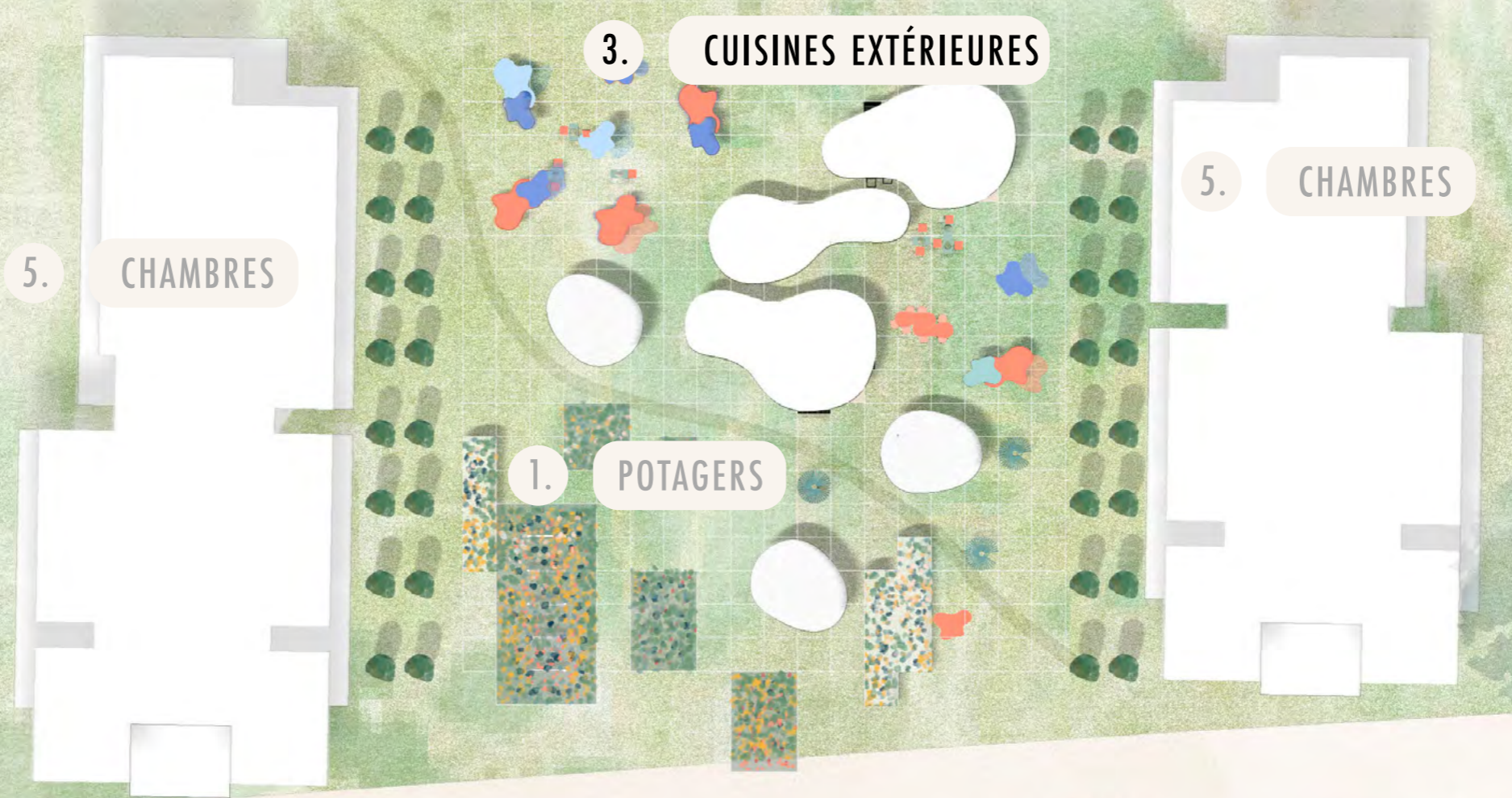
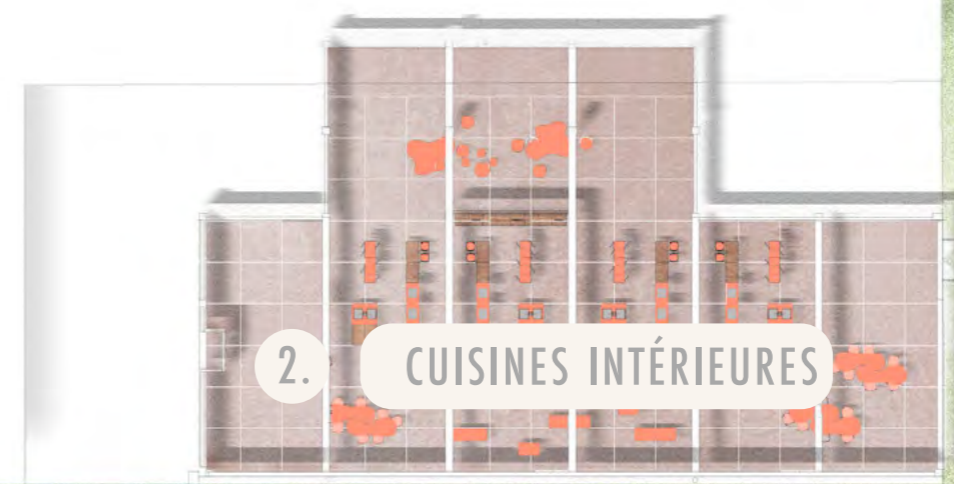

DES CUISINES EXTÉRIEURES

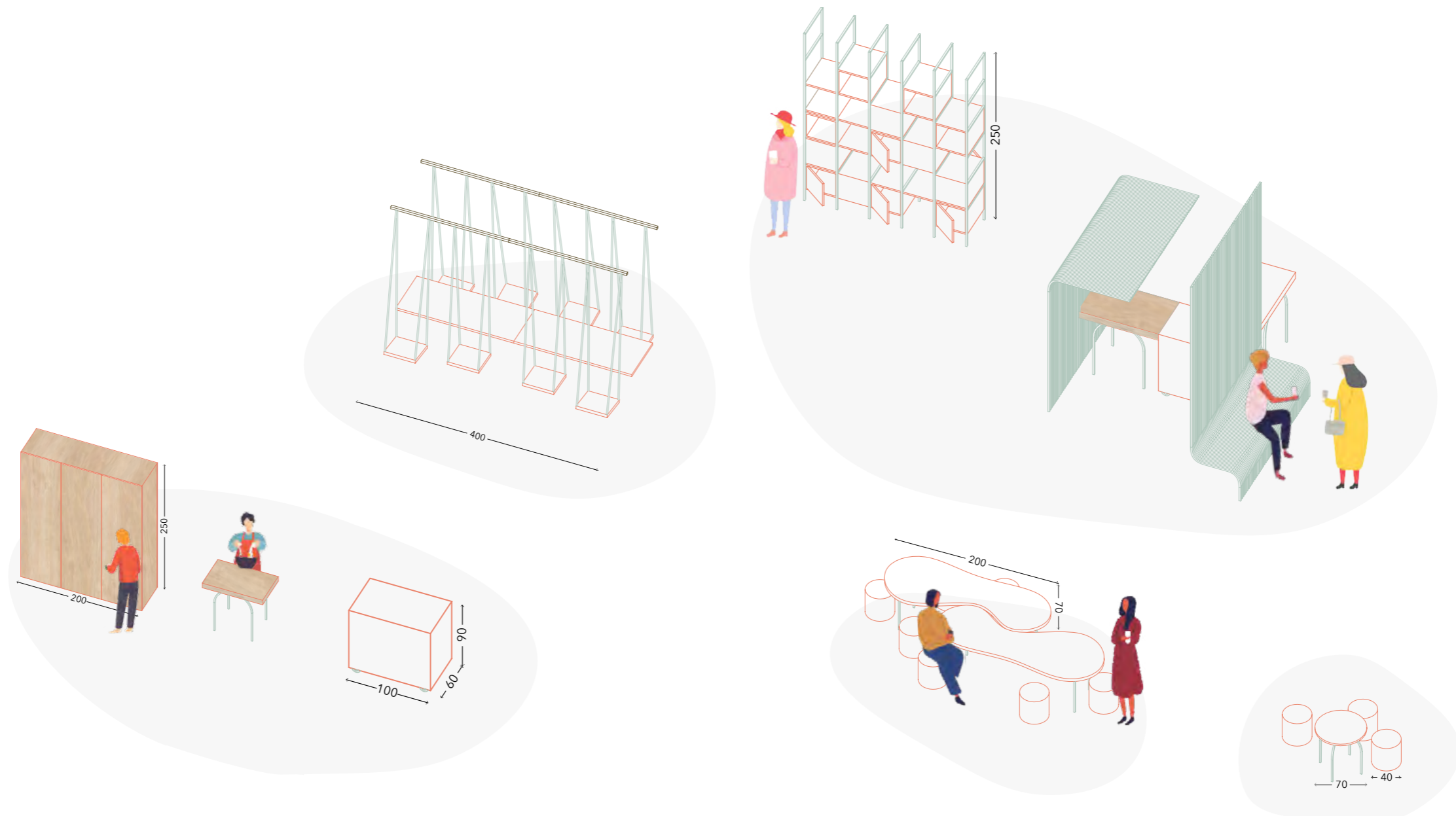

Nouveau Paysage

Chair mutation des vies étudiantes

© Jingyu Yan - Carla Genty - Diane-Line Farré

INVESTIR LE PAYSAGE

PRINCIPES DE CONSTRUCTION

UNE TRAME DIRECTRICE

+

UNE STRUCTURE FIXE
DES ÉLÉMENTS MODULABLES

+

PANNEAUX PLEINS / TREILLIS

TUBES LINÉAIRES

FORMES LIBRES

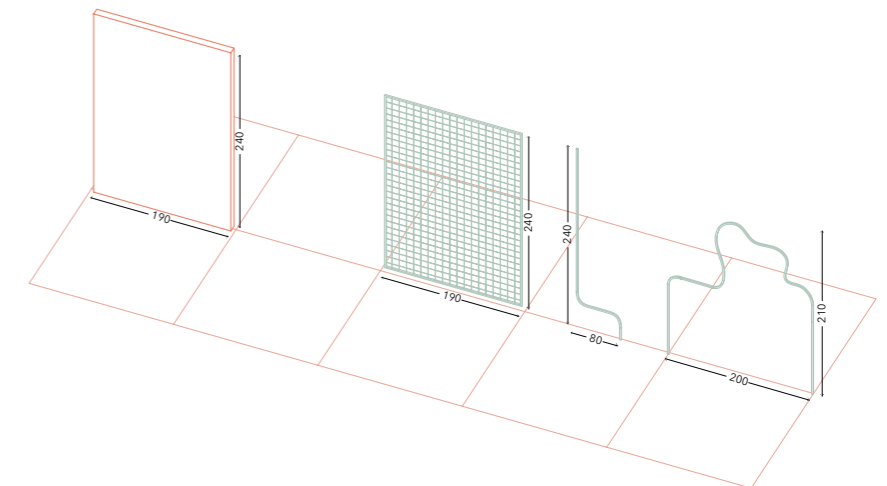
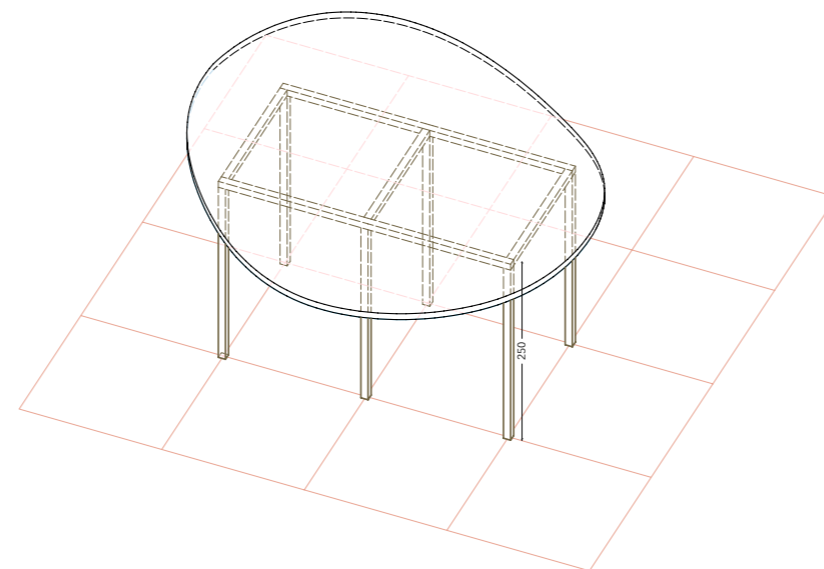
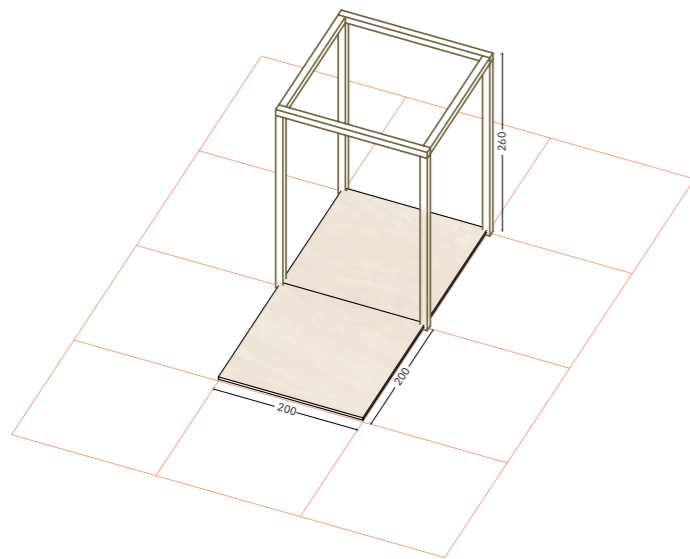

Nouveau Paysage

Chair mutation des vies étudiantes

© Jingyu Yan - Carla Genty - Diane-Line Farré

DES TABLES - BALANÇOIRES

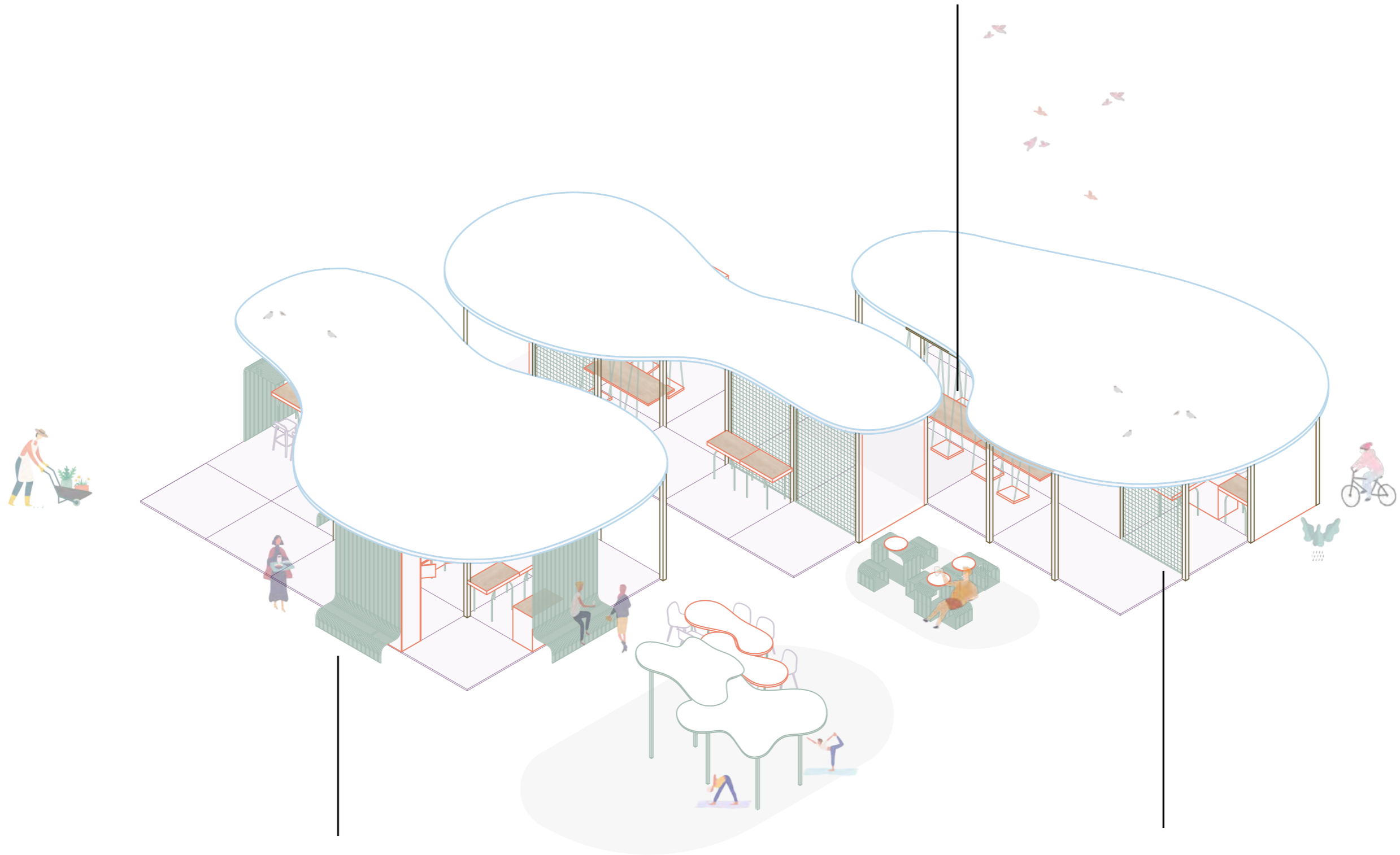

UN MOBILIER TUBULAIRE FIXE

PAROIS À VÉGÉTALISER

Nouveau Paysage

Chair mutation des vies étudiantes

© Jingyu Yan - Carla Genty - Diane-Line Farré

DES CUISINES MOBILES

zoom

Automne-hiver

Printemps-été

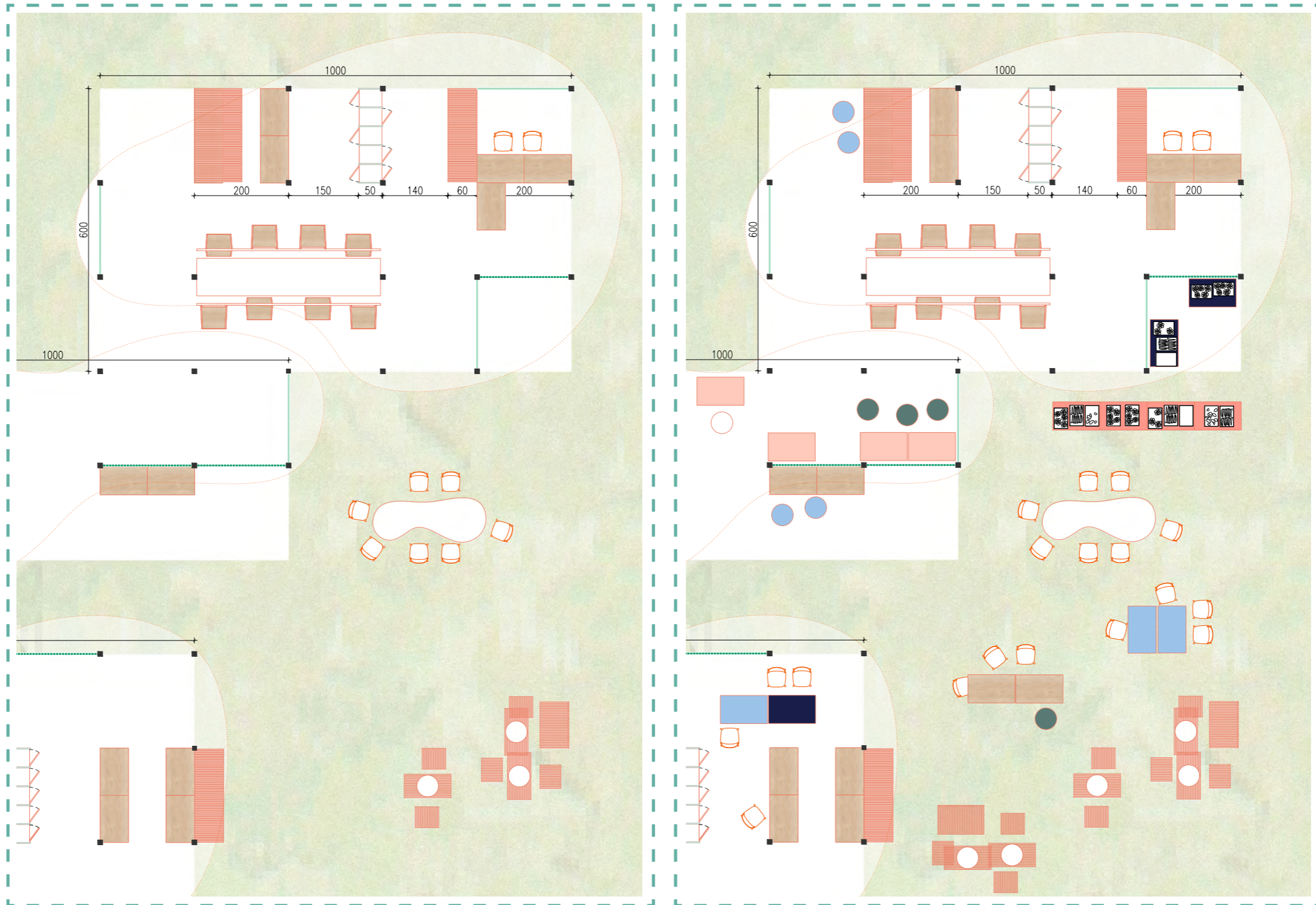

Nouveau Paysage

Chair mutation des vies étudiantes
© Jingyu Yan - Carla Genty - Diane-Line Farré



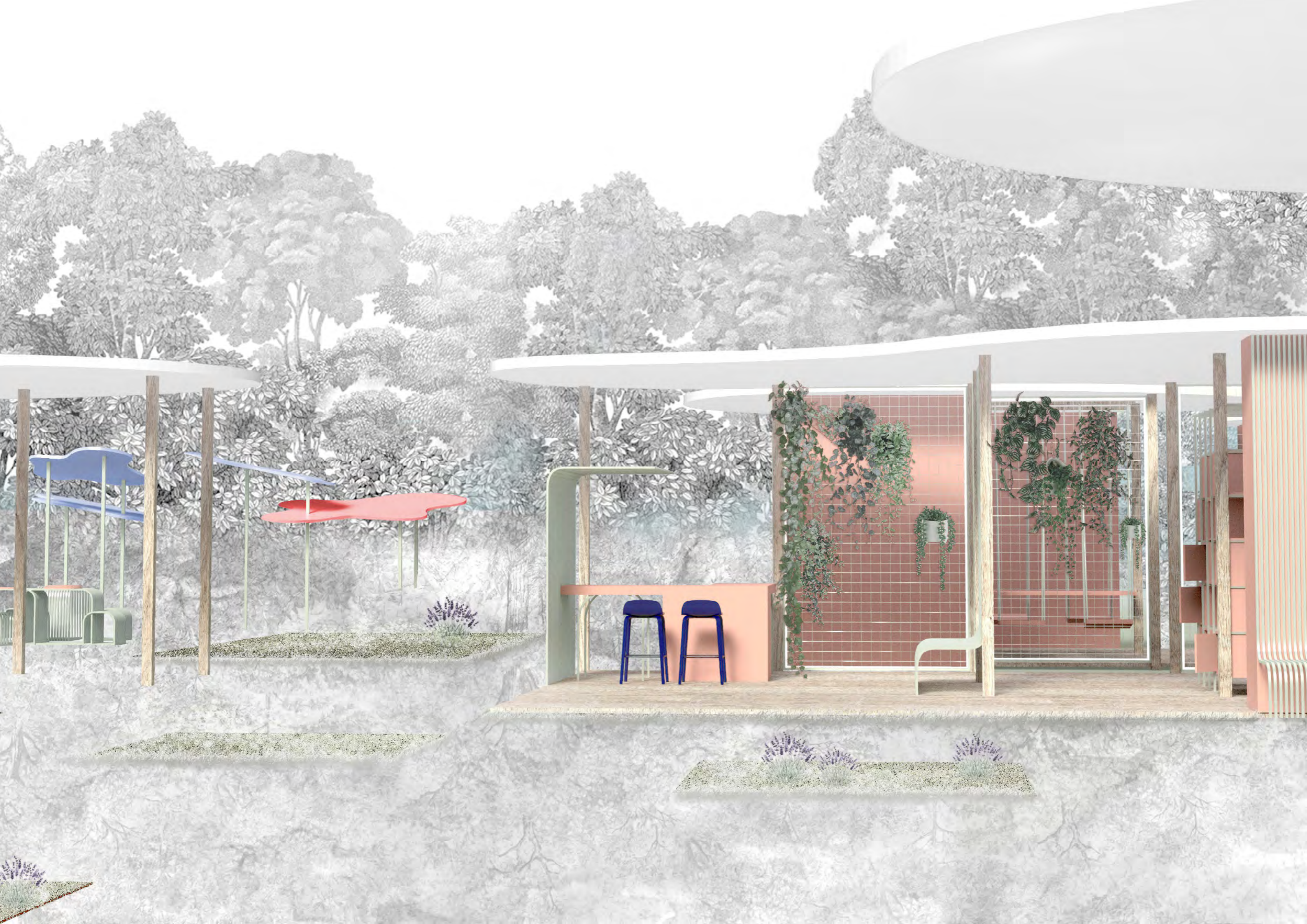

UN PAYSAGE MULTIPLE

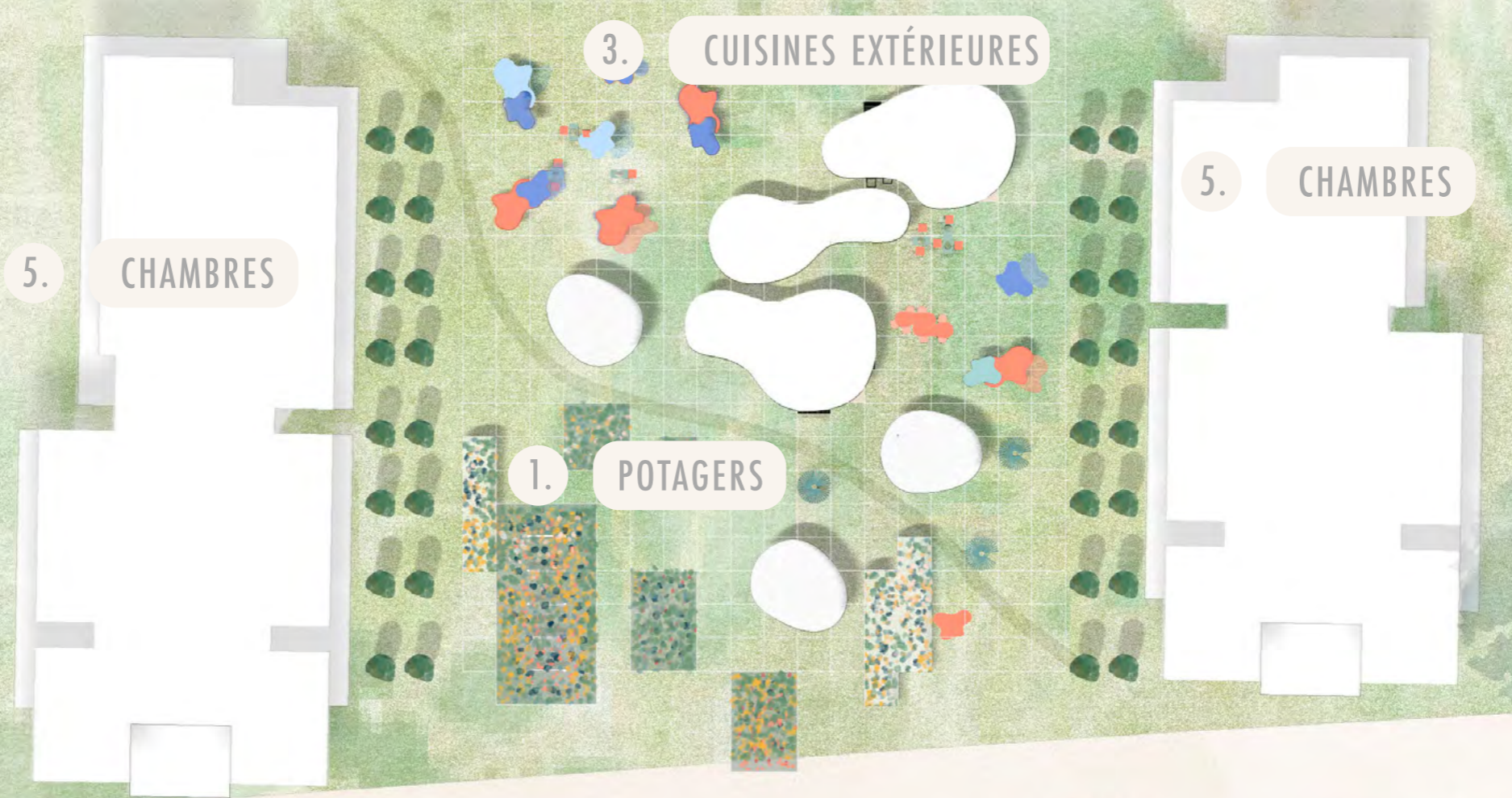
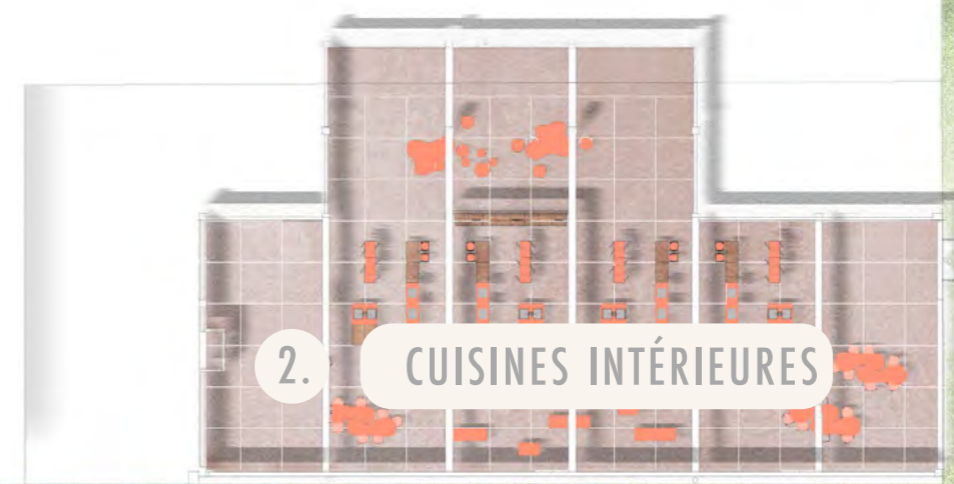

UN SITE PAYSAGER

On se promène, on découvre l'extérieur

au gré de nos activités...

À travers un mobilier fixe présentant des formes variées selon des fonctions qu'on lui attribue

nous créons des circulations

là où il n'y en existe pas encore.

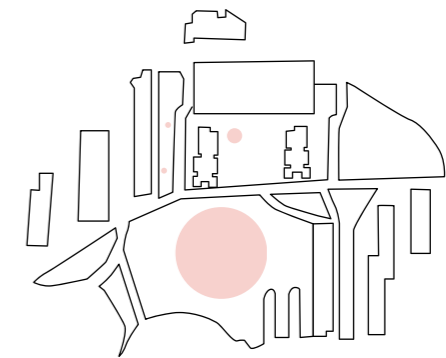
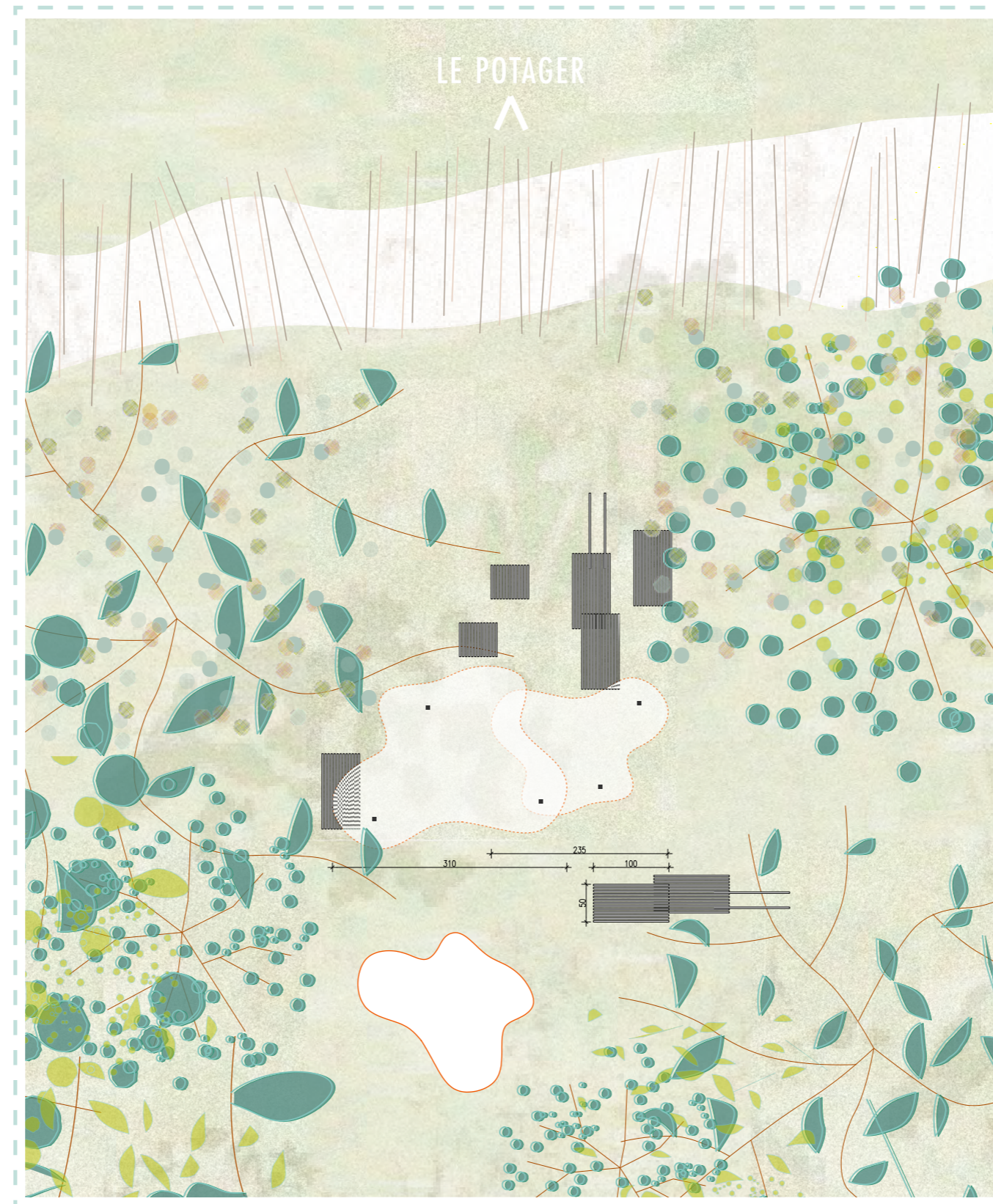

Nouveau Paysage

Chair mutation des vies étudiantes

© Jingyu Yan - Carla Genty - Diane-Line Farré



1.

LA LISIÈRE DES ARBRES

2.

LA PROMENADE MENTALE

3.

LA PROMENADE DYNAMIQUE

À LA LISIÈRE DES ARBRES

*Profiter du soleil ou s'abriter
de la pluie,*

manger un bout,

seul...

ou à plusieurs...

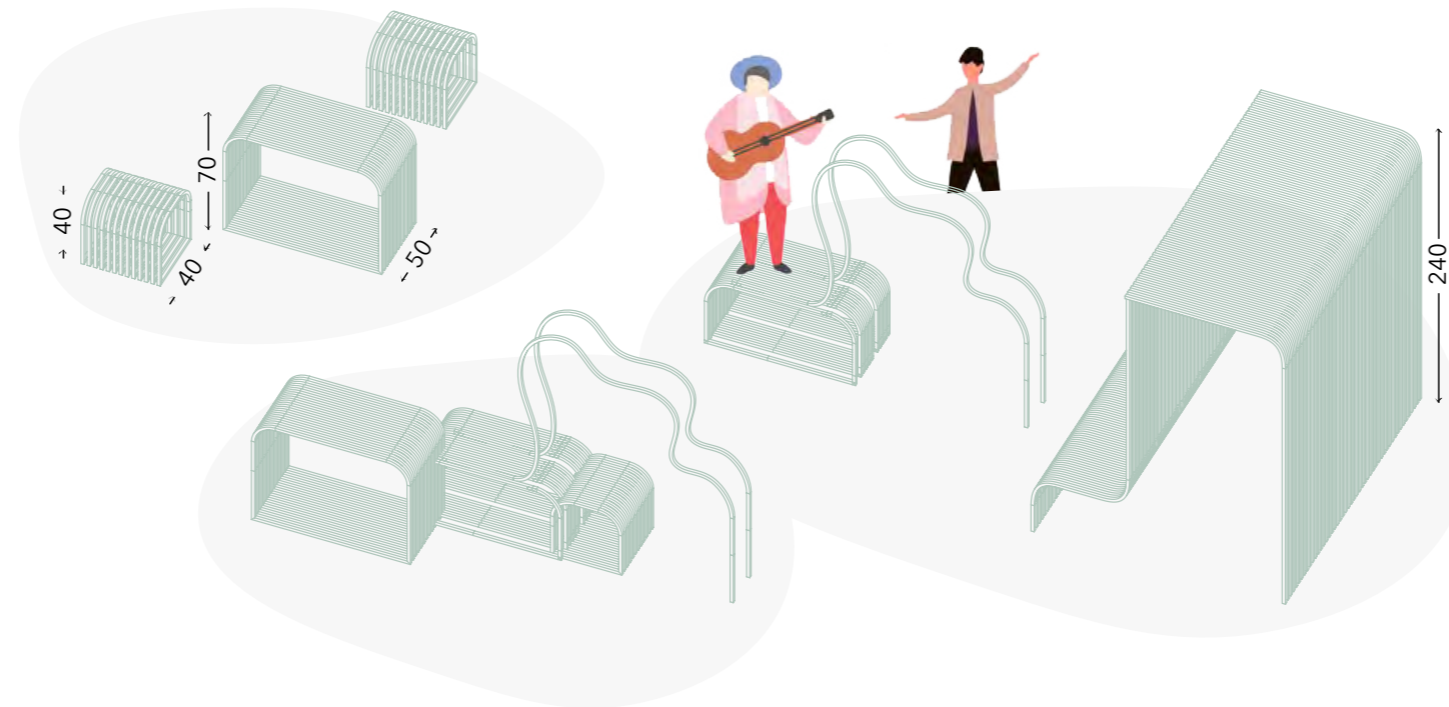
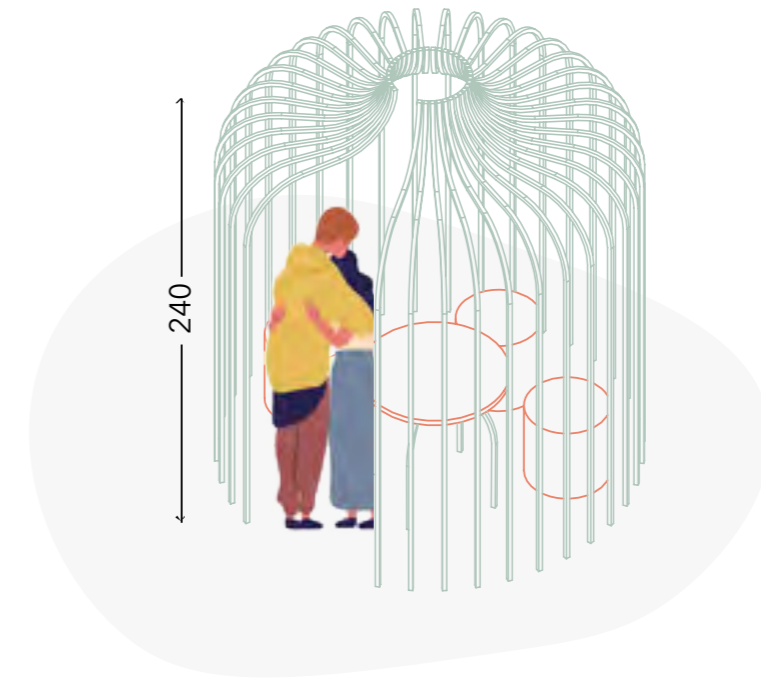

Nouveau Paysage

Chair mutation des vies étudiantes

© Jingyu Yan - Carla Genty - Diane-Line Farré

À LA LISIÈRE DES ARBRES

ABRIS & FORMES LIBRES

ASSISES ET TABLES

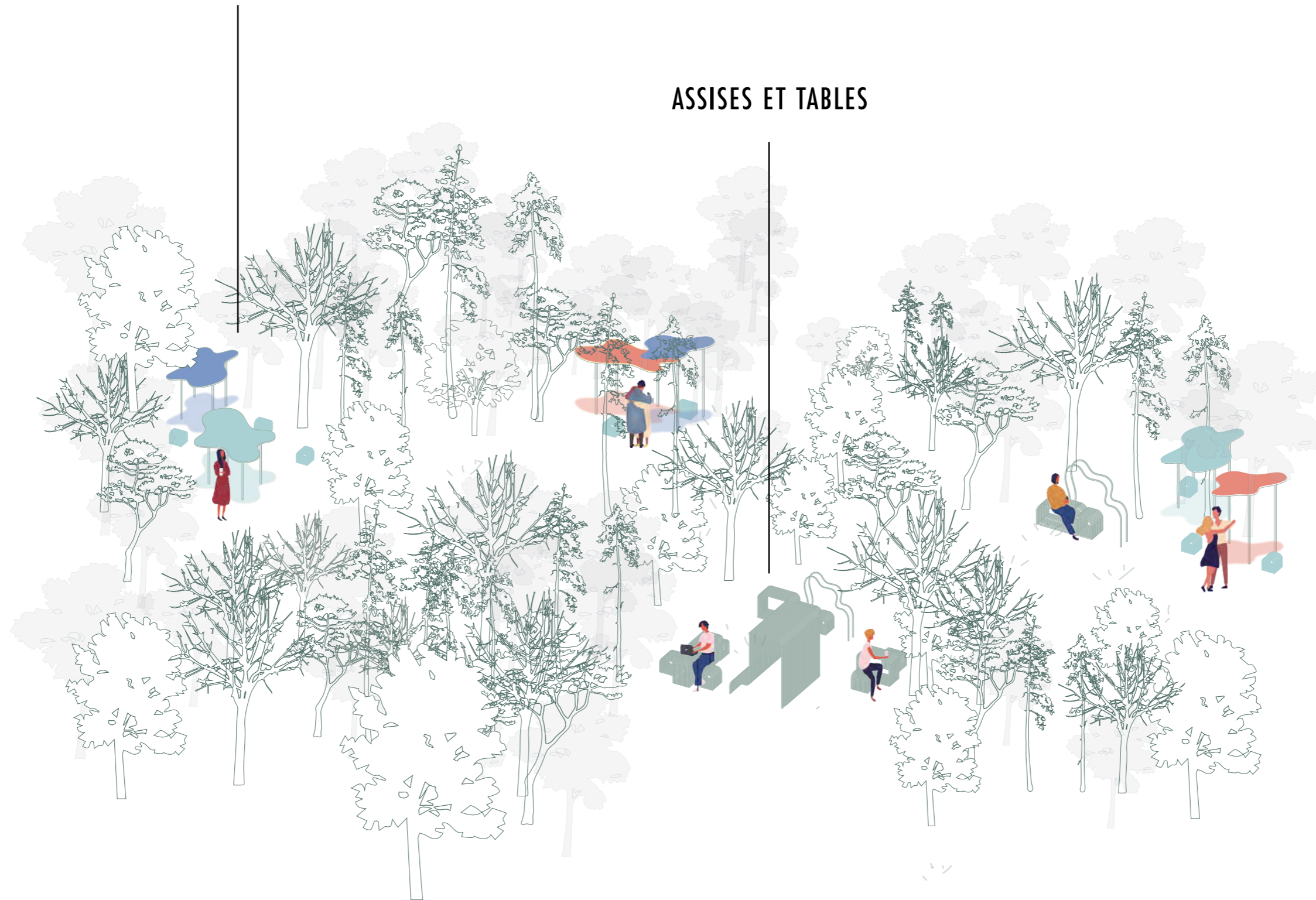

Nouveau Paysage

Chair mutation des vies étudiantes

© Jingyu Yan - Carla Genty - Diane-Line Farré

LA PROMENADE MENTALE



*S'étirer, s'étaler,
se réunir*



*Méditer, lire,
s'allonger, rêver
et s'endormir...*



*Écouter,
jouer de la
musique, créer
l'événement*

Nouveau Paysage

Chair mutation des vies étudiantes

© Jingyu Yan - Carla Genty - Diane-Line Farré

LA PROMENADE MENTALE

ASSISES ET TABLES À DÉPLACER

ABRIS & FORMES AU SOL

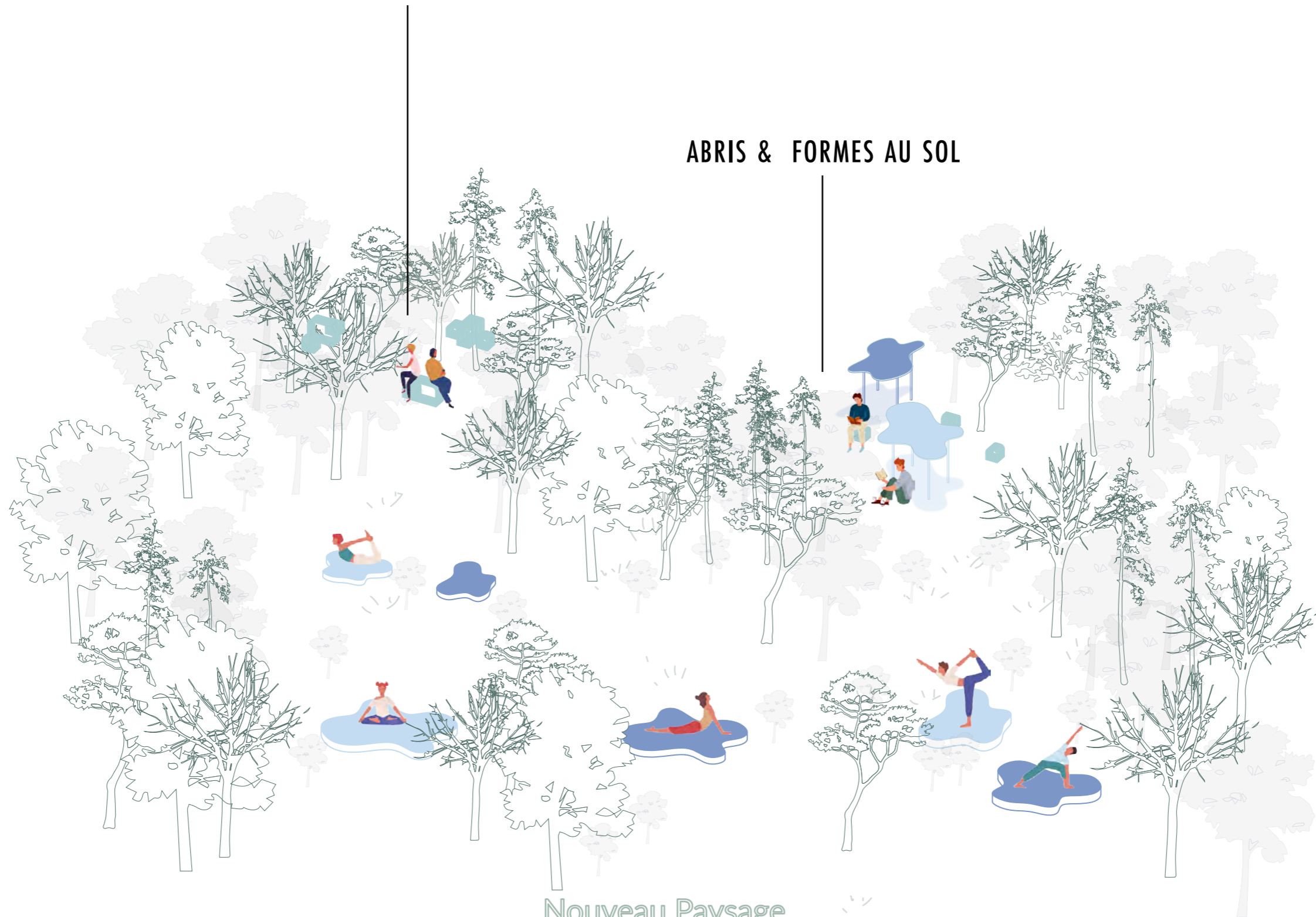

Nouveau Paysage

Chair mutation des vies étudiantes

© Jingyu Yan - Carla Genty - Diane-Line Farré

LA PROMENADE DYNAMIQUE

COURIR

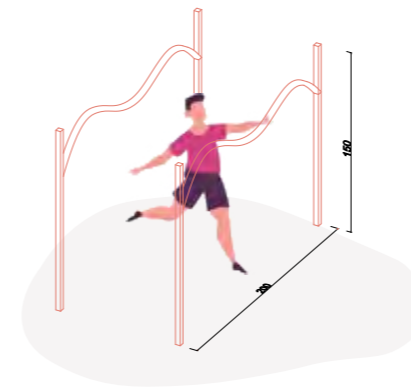

SAUTER



GRIMPER

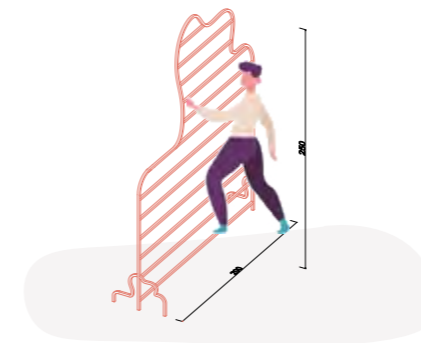

S'ÉTIRER...



SE BALANCER



*Avons-nous encore le droit
de faire preuve d'autant de légèreté ?*

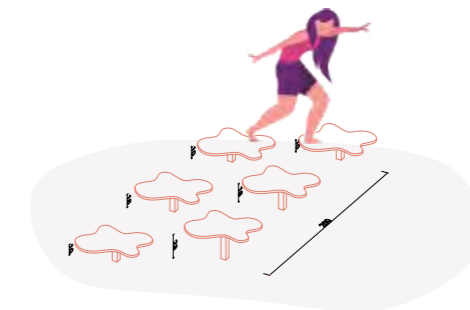

*De jouer avec
les formes,
les courbes,*

Tout cela à l'écart

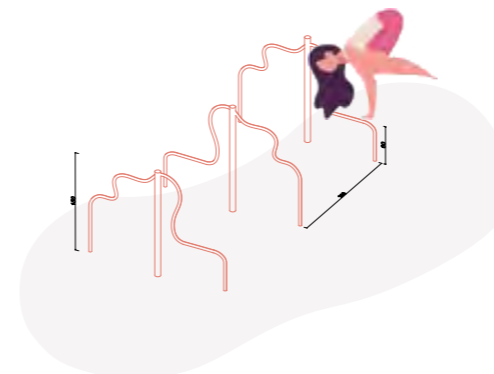

...au calme

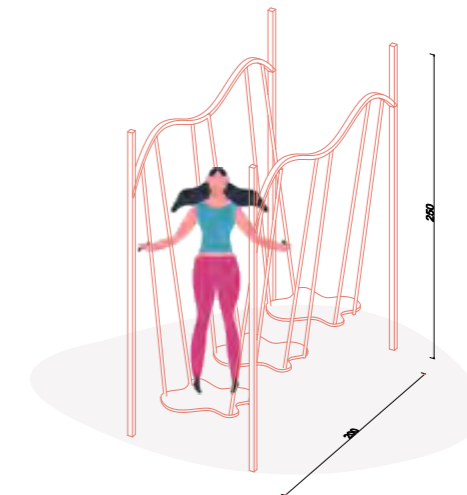

Nouveau Paysage

Chair mutation des vies étudiantes

© Jingyu Yan - Carla Genty - Diane-Line Farré

LA PROMENADE DYNAMIQUE

UN MOBILIER «FOU», À LA
LISIÈRE DU STADE DE SPORT



Nouveau Paysage

Chair mutation des vies étudiantes

© Jingyu Yan - Carla Genty - Diane-Line Farré

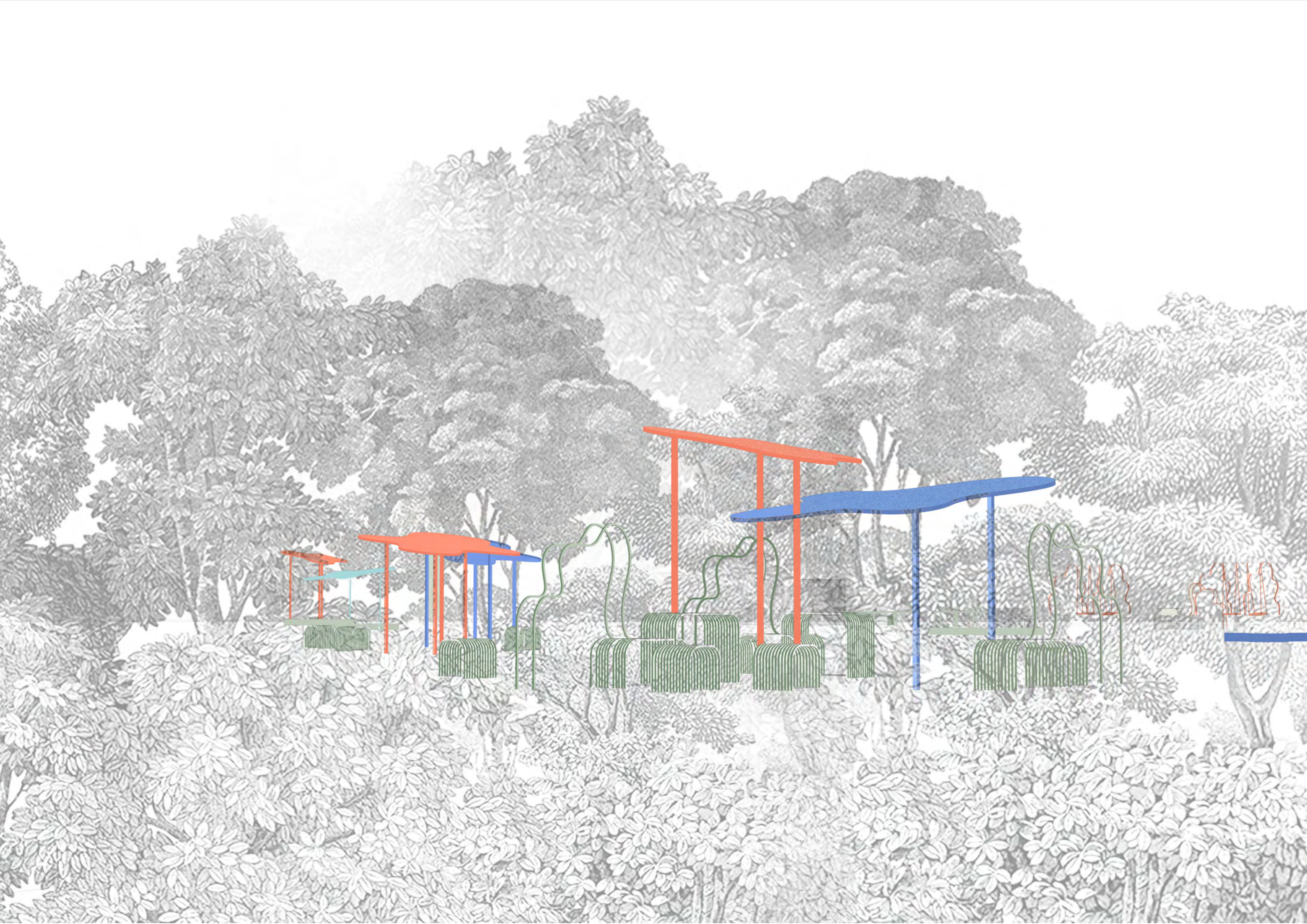

UN PAYSAGE MULTIPLE

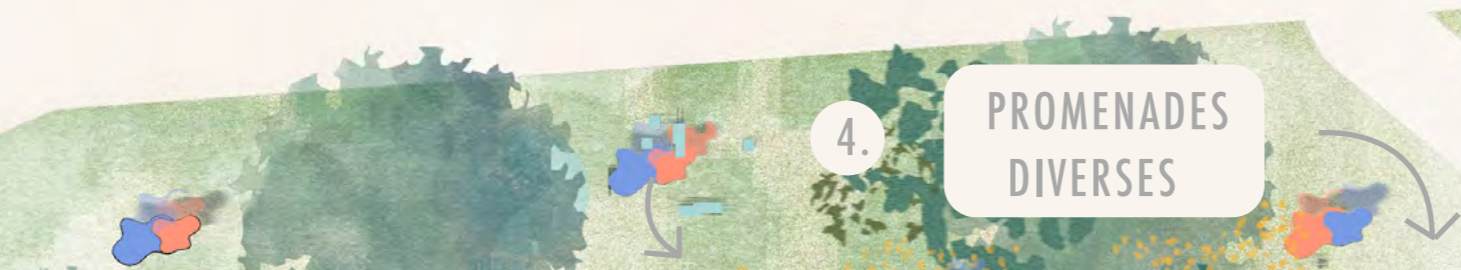
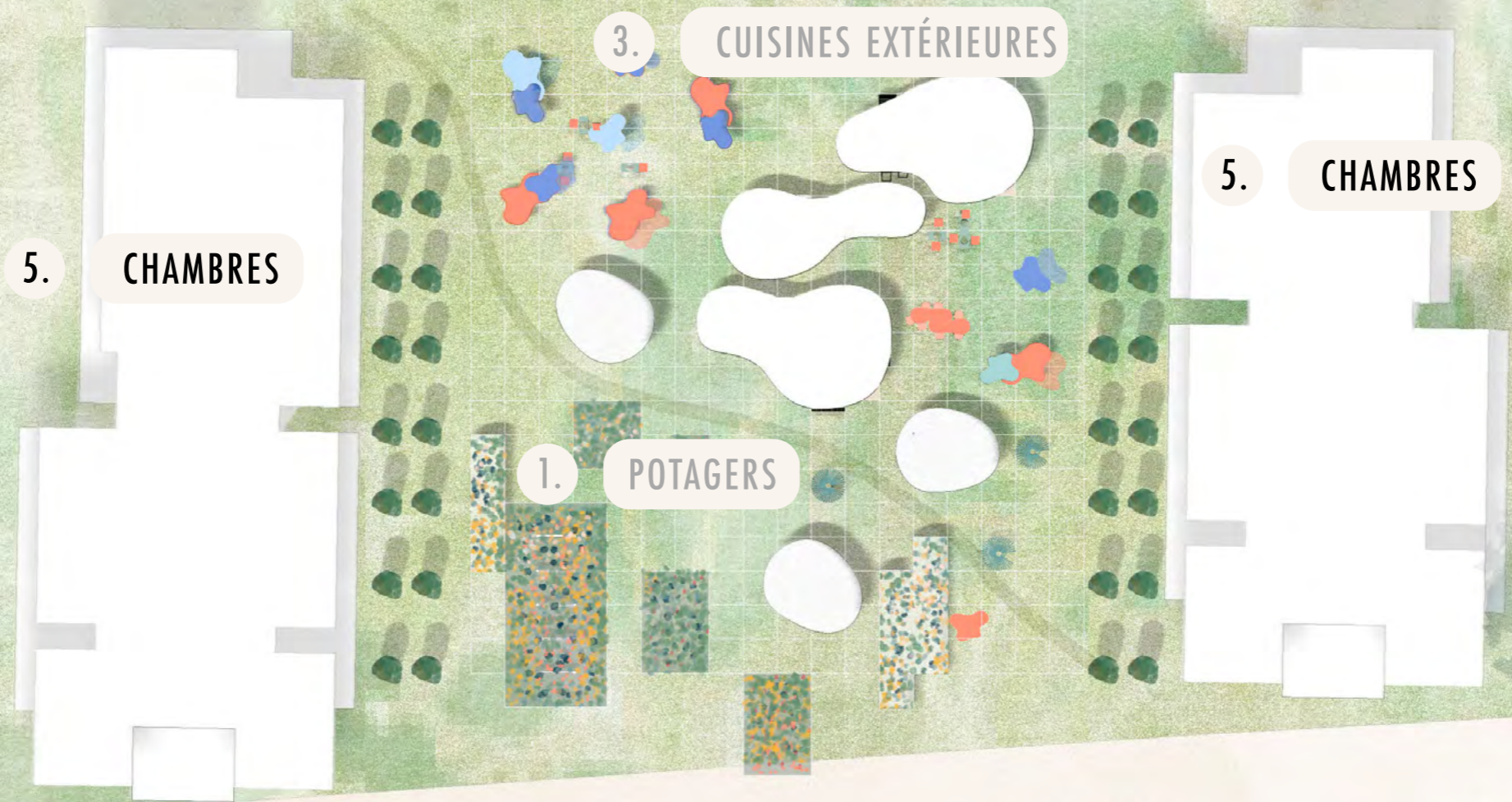
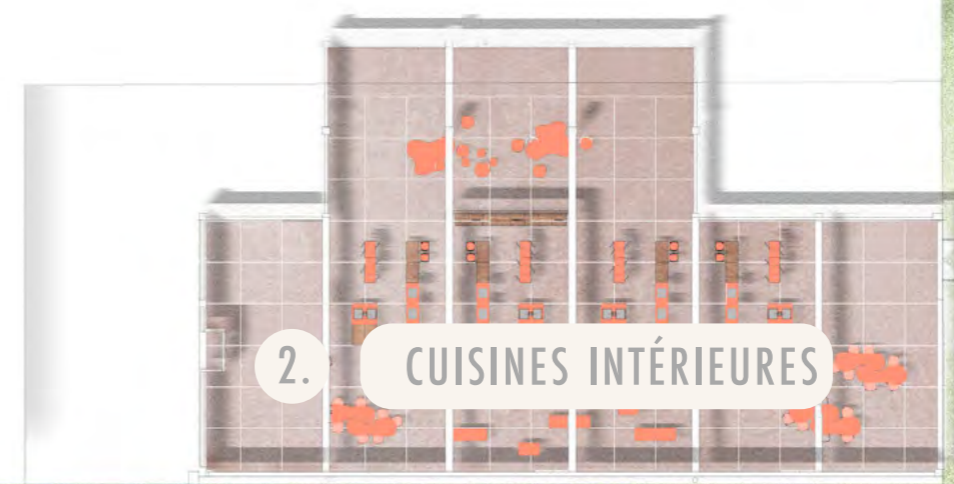

UNE CHAMBRE AUGMENTÉE



Nouveau Paysage

Chair mutation des vies étudiantes

© Jingyu Yan - Carla Genty - Diane-Line Farré

TYOLOGIE DE LA CHAMBRE

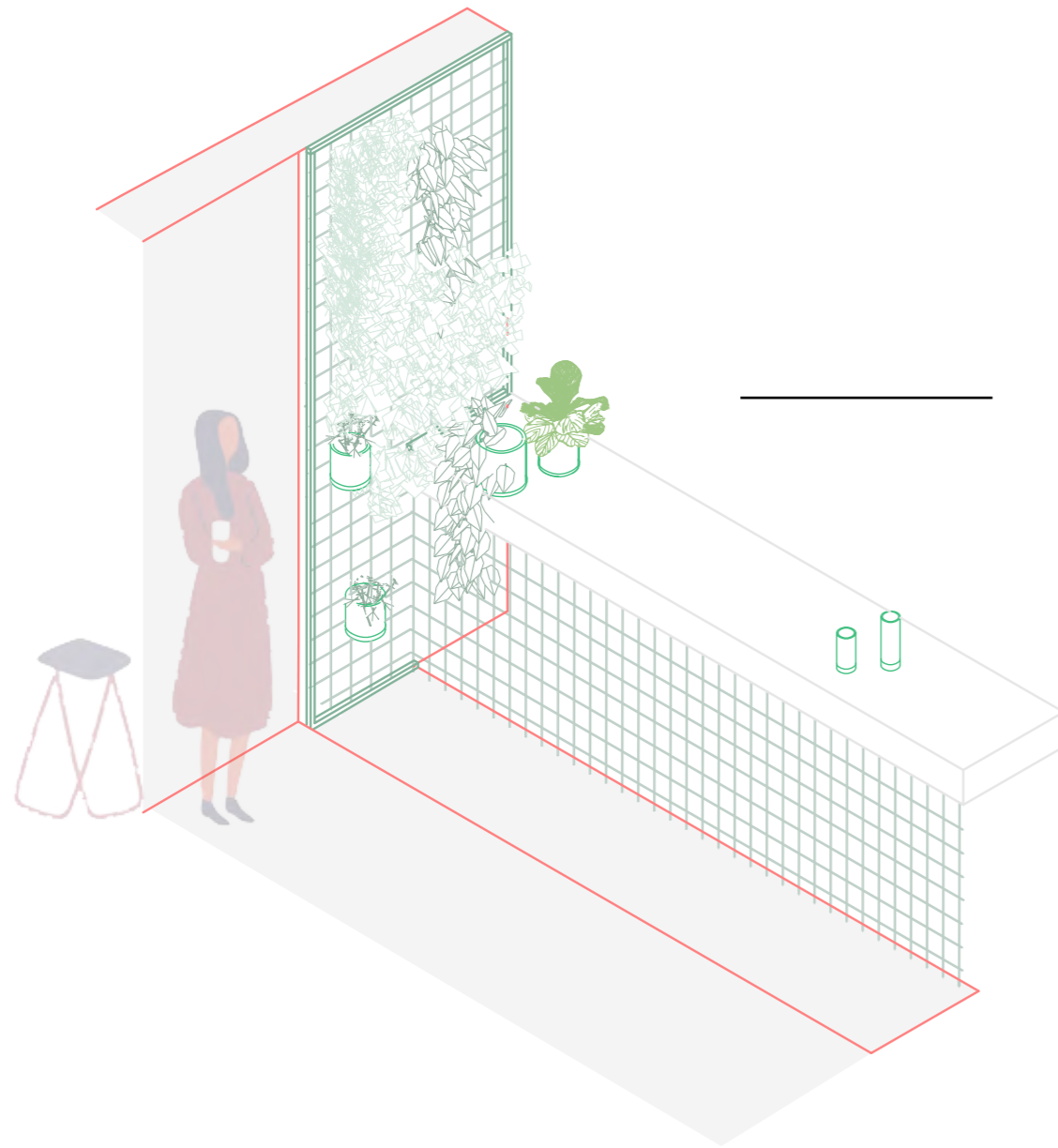

TREILLIS RECOUVRANT LES MURS DU BALCON

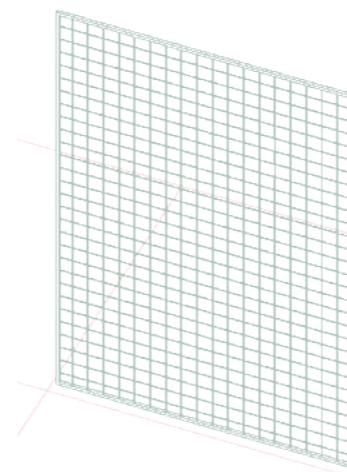

+

PLANTES À SEMER, FAIRE GRANDIR ET RÉPARTIR

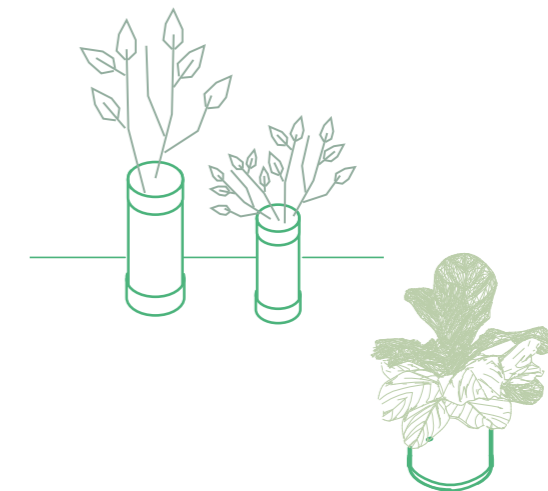

Donner à chaque étudiant les éléments de connexion à la vie partagée

Pourquoi ne pas planter ensemble..

...et récolter pour la chambre ?

Nouveau Paysage

Chair mutation des vies étudiantes

© Jingyu Yan - Carla Genty - Diane-Line Farré

UN ESPACE ALLÉGÉ : DES STRUCTURES FINES

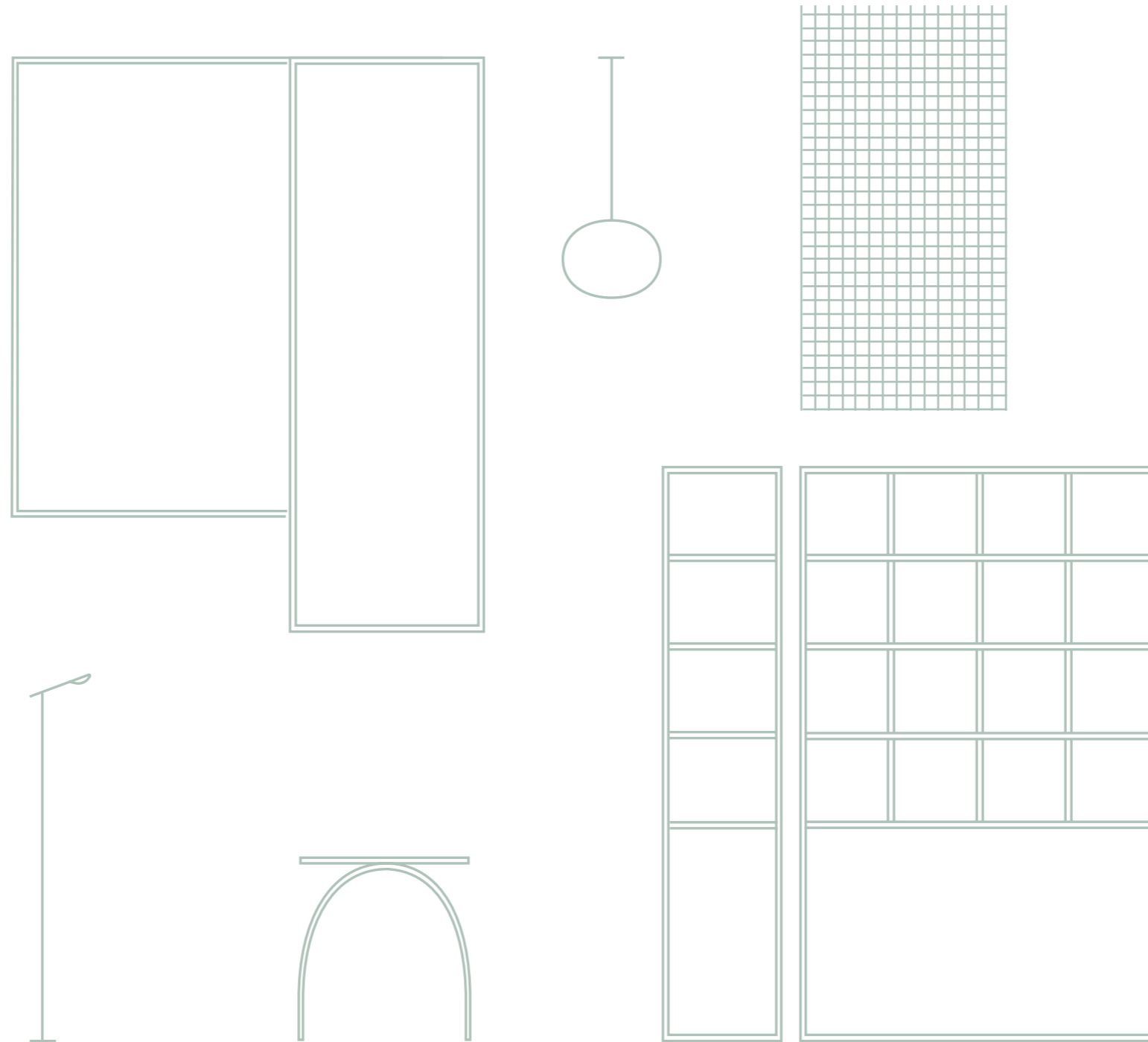

Nouveau Paysage

Chair mutation des vies étudiantes

© Jingyu Yan - Carla Genty - Diane-Line Farré

ÉTENDRE LA CHAMBRE AU PAYSAGE, INVENTER
UNE NOUVELLE FENÊTRE



Nouveau Paysage

Chair mutation des vies étudiantes

© Jingyu Yan - Carla Genty - Diane-Line Farré

UN BALCON VIVANT



Nouveau Paysage

Chair mutation des vies étudiantes

© Jingyu Yan - Carla Genty - Diane-Line Farré

UN BALCON PARTAGÉ

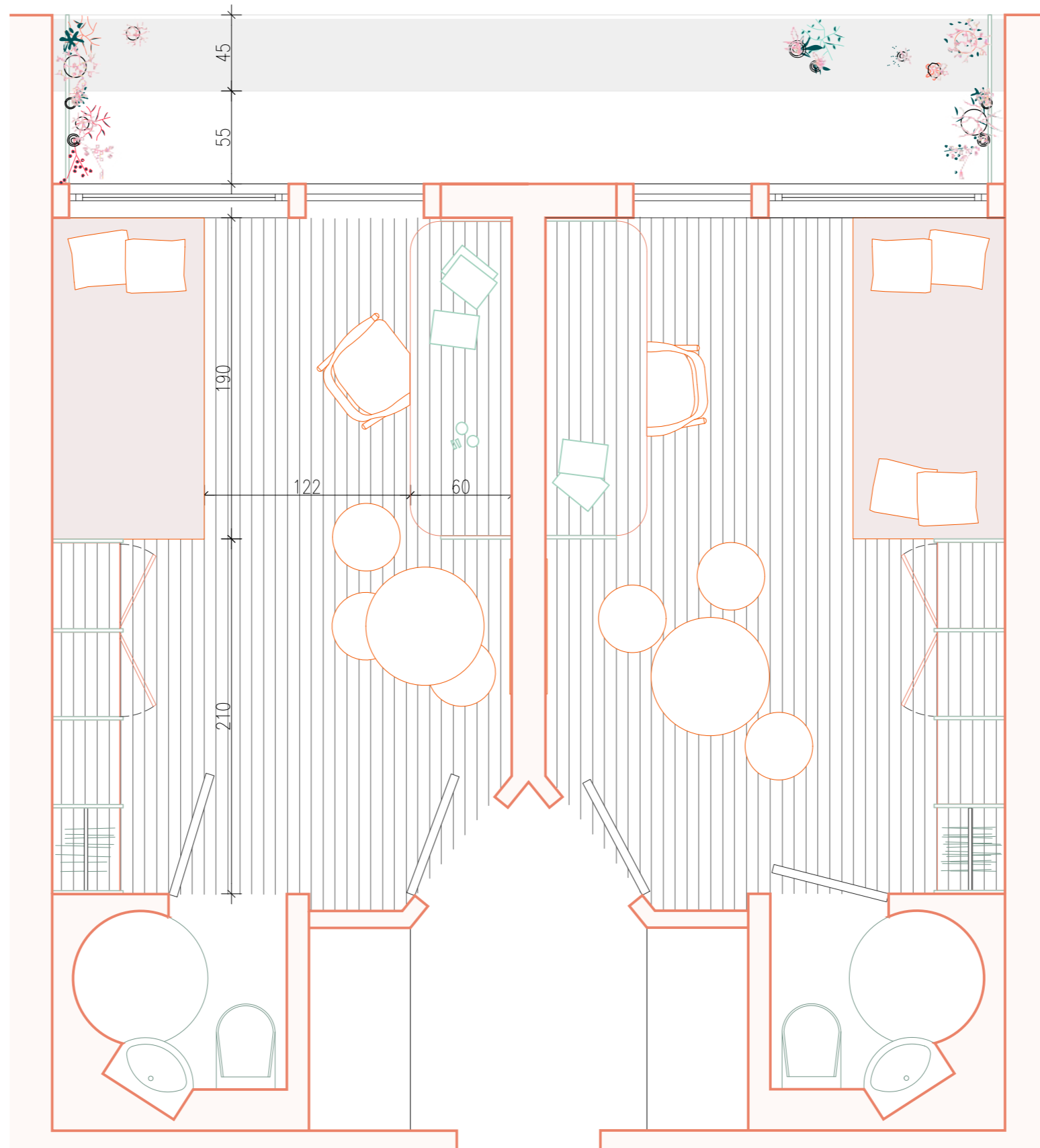

Nouveau Paysage

Chair mutation des vies étudiantes

© Jingyu Yan - Carla Genty - Diane-Line Farré



DES MATÉRIAUX ET DES FORMES

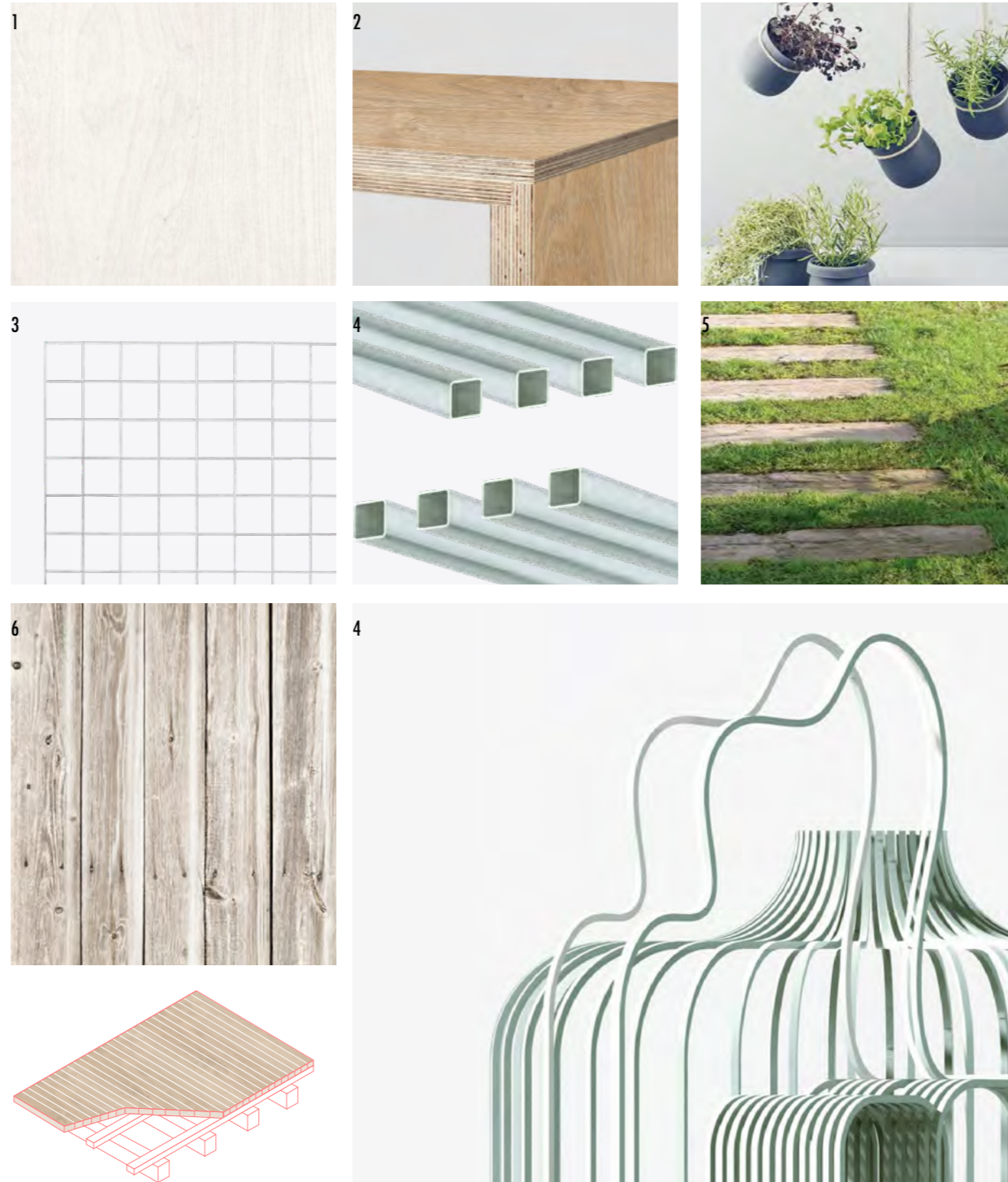

1. Parois extérieures (cuisine) en contreplaqué stratifié et traité aspect bois clair (type Parplex)
2. Mobilier fixe et mobile en contreplaqué, stratifié aspect chêne + gamme de couleur définie
3. Treillis en acier, maille carrée
4. Structures tubulaires en acier, peinture époxy «vert céladon»
5. Chemins existants et chemins créés marqués par des traverses en bois
6. Terrasse en lames de bois naturelles (planches préfabriquées) sur vis de fondation ajustables.

Nouveau Paysage

Chair mutation des vies étudiantes

© Jingyu Yan - Carla Genty - Diane-Line Farré

UN PAYSAGE DE COULEURS

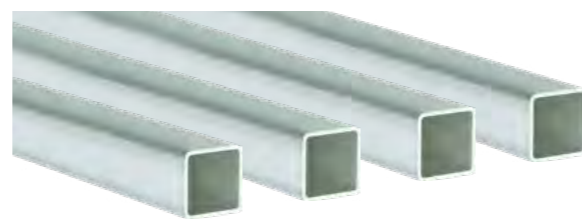

ASPECT DE L'ACIER PEINT EXTÉRIEUR

STRUCTURES TUBULAIRES EN
ACIER, PEINTURE ÉPOXY
«VERT CÉLADON»



GAMME DE COULEUR - MOBILIER BOIS



Nouveau Paysage

Chair mutation des vies étudiantes

© Jingyu Yan - Carla Genty - Diane-Line Farré

AGENCEMENT COLORÉ

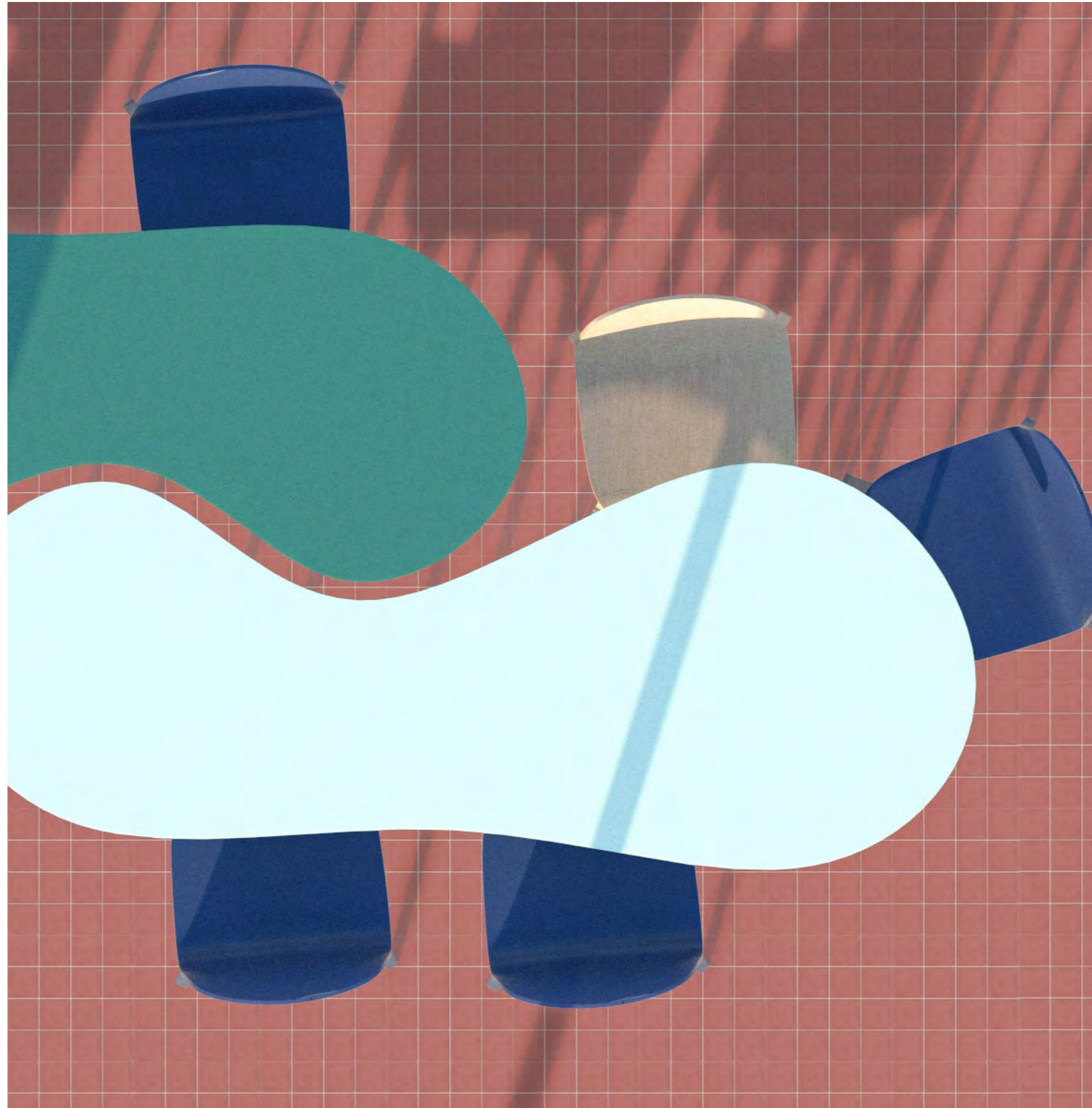

Nouveau Paysage

Chair mutation des vies étudiantes

© Jingyu Yan - Carla Genty - Diane-Line Farré

CUISINES VIVANTES



Nouveau Paysage

Chair mutation des vies étudiantes

© Jingyu Yan - Carla Genty - Diane-Line Farré

UN PAYSAGE DE NUIT

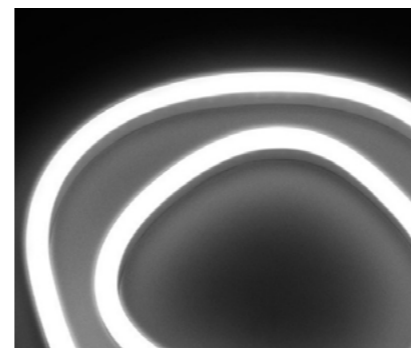
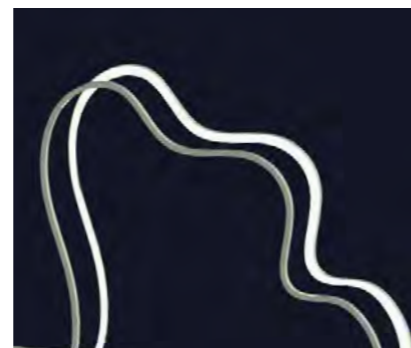

Nouveau Paysage

Chair mutation des vies étudiantes

© Jingyu Yan - Carla Genty - Diane-Line Farré

